

## 兩爪自定心卡盤 (前後鎖通用)

SCT 2 jaw scroll chuck (Front and back mounting)

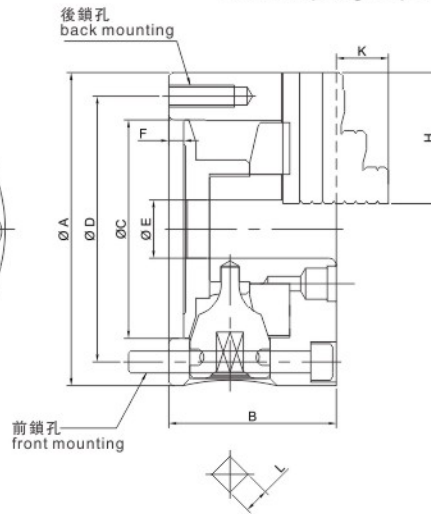
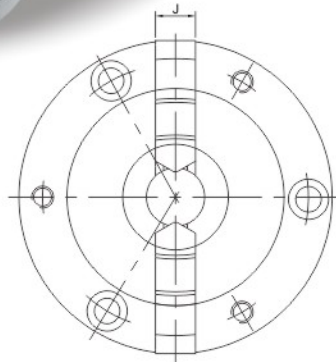

- 1. 直口連接
- 2. 標配一體式正反爪各一組
- 3. 重複夾持精度為0.03mm
- 1. Plain back
- 2. Standard accessories: 1 set outside solid jaws and 1 set inside solid jaws
- 3. Clamping repeatability is 0.03mm

### 規格 / Specification

單位/UNIT:mm

型式/規格 Model/Spec	最大容許扭矩 Max. Allowable Torque N*m	最大靜夾持力 Max. Gripping Force KN	淨重 Weight Kg	最高轉速 RPM	夾持範圍外徑 O.D Clamping Range mm	夾持範圍內徑 I.D. Clamping Range mm
SCT-04*	44	12	3.1	2500	3-90	32-84
SCT-05*	63	15	4.4	2500	3-110	35-100
SCT-06	88	31	11.4	2000	3-160	48-150
SCT-07	107	31	12.2	2000	4-180	56-170
SCT-08	128	33	16.2	2000	4-180	56-170
SCT-09	147	37	21.2	2000	5-220	62-210
SCT-10	176	46	28	1800	6-260	70-250

型式/規格 Model/Spec	A	B	C	D	E	F	G	H	J	K	L
SCT-04*	112	58	80	95	24	4.5	3(4)-M8x1.25P	42	15	31	8
SCT-05*	132	60	100	115	32	4.5	3(4)-M8x1.25P	51	20	40	8
SCT-06	167	66	130	147	45	5	3-M10x1.5P	70	20	53	10
SCT-07	193	76	155	172	58	5	3-M10x1.5P	85	25	54	11
SCT-08	203	76	160	176	58	5	3-M10x1.5P	85	25	54	11
SCT-09	233	84	190	210	70	5.5	3-M12x1.75P	105	28	63	12
SCT-10	273	86	230	250	89	5.5	3-M12x1.75P	105	28	63	12

\*注：前端連接螺絲為4個； Note: The front mounting bolts are 4pcs

\* 保留技術更改的權利，恕不另行通知 Subject to technology changes without prior information

\* 非標需求可訂做 Non-standard requirements can be made