

## ► B SERIES

中空動力夾頭 (三爪高速中空型)

3-JAW THOUGH HOLE POWER CHUCK



- ◎ 楔形三爪大貫通孔徑。
- ◎ 摺動面均經硬化及精密研磨，并直接潤滑。
- ◎ 高剛性結構及高夾持精度。
- ◎ It's a WEDGE-HOOK type 3-jaw with the large through-hole.
- ◎ Matching surfaces of all parts hardened, ground and lubricated directly
- ◎ Construction of high rigidity and high clamping accuracy.

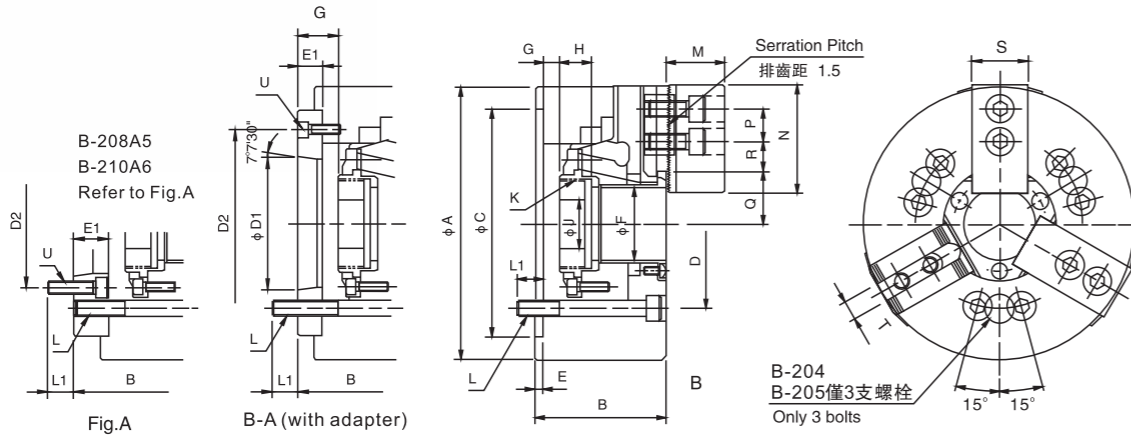

規格 Spec 型號 Model	楔心行程(mm) Plunger stroke	爪行程(直徑) Jaw stroke (Dia.) (mm)	夾持直徑 chucking Dia.(mm)		容許油壓缸推力 Max.D.B.Pull (kgf)	最大夾持力 Max clamping force (kgf)	最高回轉速 max r.p.m	慣性矩 kg·m <sup>2</sup>	重量 (kg) Weight	適合油壓缸 Matched cylinders
			最大Max	最小Min						
B-204	10	5.4	110	7	1400	2900	8000	0.01	4	H-0928
B-205 A4	10	5.4	135	12	1750	3650	7000	0.02	6.7 7.5	H-1036
B-206 A5	12	5.5	169	15	2200	5800	6000	0.06	11.9 13.7	H-1246
B-208 A5 A6	16	7.4	210	13	3450	8550	5000	0.18	22.5 25.4 23.6	H-1552
B-210 A6 A8	19	8.8	254	31	4350	11300	4200	0.33	34.5 41.5 40	H-1875
B-212 A8	23	10.6	304	34	5600	14650	3300	0.77	61 64	H-2091
B-215 A11	23	10.6	381	50	7240	18350	2500	2.39	120 127	H-2511
B-218 A11	23	10.6	450	50	7240	18355	2000	3.74	164 178	H-2511
B-220 A15	23	10.6	510	120	9177	23861	1800	6.91	223 234	ML2816
B-224 A20	26	12	610	150	9177	23861	1400	15.67	270 286	ML3320
B-232 A20	34	18	800	210	10197	24472	1200	43	546 560	ML3320

## ► B SERIES

中空動力夾頭 (三爪高速中空型)

3-JAW THOUGH HOLE POWER CHUCK

寸法 Size 型號 Model	A	B	C(H6)	D	D1	D2	E	E1	F	Gmax	Gmin	H	J
B-204	110	59	85	70.6	-	-	-	-	26	3.5	-6.5	17.5	12
B-205 A4	135	60	71	110	82.6	63.51	96	4	15	33	1	16	20
B-206 A5	169	81	91	140	104.8	82.56	116	5	45	11	26	-1	14
B-208 A5 A6	210	91	109 103	170	133.4	104.8 150	106.38	5	23 17	45 52	11 14.5	37.5 31.5	-1.5 15.5
B-210 A6 A8	254	100	120 113	220	171.5	133.4 190	139.72	6	25 18	75 8.5	8.5 26.5	-10.5 7.5	14.5 25
B-212 A8	304	110	122	300	235	196.87	260	6	22	117.5	11	33	-12
B-215 A11	381	133	149	300	235	196.87	260	6	22	117.5	7	29	-16
B-218 A11	450	133	149	300	235	196.87	260	6	27	180	11	38	-12
B-220 A15	510	134	155	380	330.2	285.78	330.2	6	25	205	16	41	-10
B-224 A20	610	147	166	520	463.6	412.78	463.6	6	25	230	16	41	-18
B-232 A20	800	150	169	520	463.6	412.78	463.6	6	25	230	16	41	-18

寸法 Size 型號 Model	K max.	L	L1	M	N	P	Q max	Q min	R max	R min	S	T	U
B-204	M32 x 1.5	3-M10	16	24	52	14	23	20.3	11.3	6.8	23	10	-
B-205 A4	M40 x 1.5	3-M10	15	15	31	62	26.5	23.8	19.8	7.8	25	12	3-M6
B-206 A5	M55 x 2	6-M10	16	16	37	73	32	29.3	22.8	9.3	31	12	6-M10
B-208 A5 A6	M60 x 2	6-M12	20	18	38	95	38.7	35	29.8	14.8	35	14	3-M6
B-210 A6 A8	M85 x 2	6-M16	22	24	43	110	51	46.6	33.8	14.3	40	16	6-M12
B-212 A8	M100 x 2	6-M16	23	25	51	130	61.3	56	45.8	15.8	50	21	3-M8
B-215 A11	M130 x 2	6-M20	30	28	66	165	82	76.7	46.8	13.8	62	25	3-M10
B-218 A11	M130 x 2	6-M20	35	28	66	165	82	76.7	46.8	13.8	62	25	3-M10
B-220 A15	M190 x 3	6-M24	35	33	73	180	112.5	107.2	60.5	24.5	64	25	3-M12
B-224 A20	M215 x 3	6-M24	35	35	73	180	139.9	133.9	87.5	24.5	64	25	3-M10
B-232 A20	M250 x 3	6-M24	35	35	73	180	162	153	153.5	24.5	64	25	3-M10

\* 保留技術更改的權利，恕不另行通知 Subject to technology changes without prior information  
\* 非標需求可訂做 Non-standard requirements can be made

## > BT SERIES

### 中空動力夾頭 (二爪高速中空型)

#### 2-JAW THOUGH HOLE POWER CHUCK

- ◎ 楔形二爪大貫通孔徑，特別適合异形物的夾持。
- ◎ 摺動面均經硬化及精密研磨，并直接潤滑。
- ◎ 高剛性結構及高夾持精度。
- ◎ It's a WEDGE-HOOK type 2-jaw with the large through-hole.
- ◎ Matching surfaces of all parts hardened, ground and lubricated directly.
- ◎ Construction of high rigidity and high clamping accuracy.

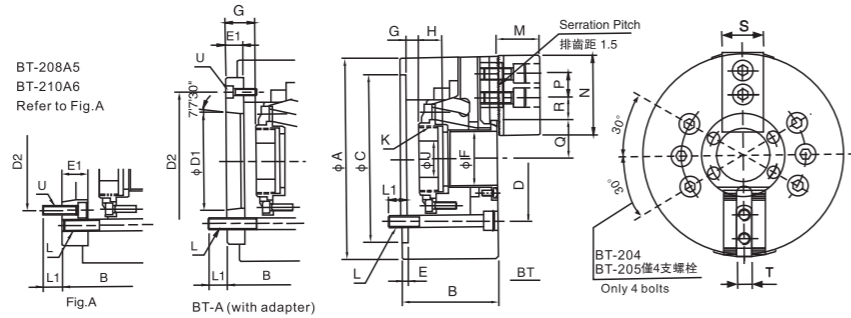

規格 Spec 型號 Model	楔行程(mm) Plunger stroke	爪行程(直徑) Jaw stroke (Dia.) (mm)	夾持直徑 chucking Dia.(mm)		容許油壓缸推力 Max. D.B. Pull (kgf)	最大夾持力 Max clamping force (kgf)	最高回轉速 max r.p.m	慣性矩 kg·m <sup>2</sup>	重量 (kg) Weight	適合油壓缸 Matched cylinders
			最大Max	最小Min						
BT-204	10	5.4	110	7	940	1930	8000	0.01	3.8	H-0928
BT-205 A4	10	5.4	135	12	1190	2440	7000	0.02	6.5 7.3	H-1036
BT-206 A5	12	5.5	169	15	1470	3870	6000	0.06	11.5 13.3	H-1246
BT-208 A5 A6	16	7.4	210	13	2360	5840	5000	0.17	21.3 24.2	H-1552
BT-210 A6 A8	19	8.8	254	31	2900	7540	4200	0.31	33.5 40.5	H-1875
BT-212 A8	23	10.6	304	34	3740	9780	3300	0.70	59.7 62.7	H-2091
BT-215 A11	23	10.6	381	50	4790	12200	2500	2.23	115 122	H-2511
BT-218 A11	23	10.6	450	50	4823	12236	2000	3.31	122 133	H-2511

寸法 Size 型號 Model	A	B	C(H6)	D	D1	D2	E	E1	F	Gmax	Gmin	H	J			
														BT-204	110	59
BT-205 A4	135	60	71	110	82.6	63.51	96	4	15	33	1	16	-9	6	20	12
BT-206 A5	169	81	91	140	104.8	82.56	116	5	23	45	11	26	-1	14	19	20
BT-208 A5 A6	210	91	109 103	170	133.4	104.8 150	150	5	17	52	14.5	37.5 31.5	-1.5	21.5 15.5	20.5	30
BT-210 A6 A8	254	100	120 113	220	171.5	106.38 133.4	133.4	5	25	75	8.5	33.5 26.5	-10.5	14.5 7.5	25	45
BT-212 A8	304	110	122					6	18	91	8	26	-15	3	28	50
BT-215 A11	381	133	149	300	235	196.87	260	6	22	117.5	11	33	-12	10	39	60
BT-218 A11	450	133	149	300	235	196.869	260	6	22	117.5	7	29	-16	6	43	-

寸法 Size 型號 Model	K max	L	L1	M	N	P	Q max	Q min	R max	R min	S	T	U
BT-204	M32 x 1.5		16	24	52		23	20.3	11.3	6.8	23		-
BT-205 A4	M40 x 1.5	3-M10	15	15	31	14	26.5	23.8	19.8	7.8	25	10	3-M6
BT-206 A5	M55 x 2	6-M10	16	16	37	20	32	29.3	22.8	9.3	31	12	
BT-208 A5 A6	M60 x 2	6-M12	20	18	38	25	38.7	35	29.8	14.8	35	14	6-M10 3-M6
BT-210 A6 A8	M85 x 2	6-M16	22	24	43	30	51	46.6	33.8	14.3	40	16	6-M12 3-M8
BT-212 A8	M100 x 2		23	25	51		61.3	56	45.8	15.8	50	21	
BT-215 A11	M130 x 2	6-M20	30	28	66	43	82	76.7	46.8	13.8	62	25	4-M10
BT-218 A11	M130x2	6-M20*135	30	28	66	43	82	76.7	79.75	15.25	62	22	3-M10

\* 保留技術更改的權利，恕不另行通知 Subject to technology changes without prior information  
\* 非標需求可訂做 Non-standard requirements can be made

## > BF SERIES

### 中空動力夾頭 (四爪高速中空型)

#### 4-JAW THOUGH HOLE POWER CHUCK

- ◎ 楔形四爪大貫通孔徑，特別適合异形物的夾持。
- ◎ 摺動面均經硬化及精密研磨，并直接潤滑。
- ◎ 高剛性結構及高夾持精度。
- ◎ It's a WEDGE-HOOK type 4-jaw with the large through-hole.
- ◎ Matching surfaces of all parts hardened, ground and lubricated directly.
- ◎ Construction of high rigidity and high clamping accuracy.

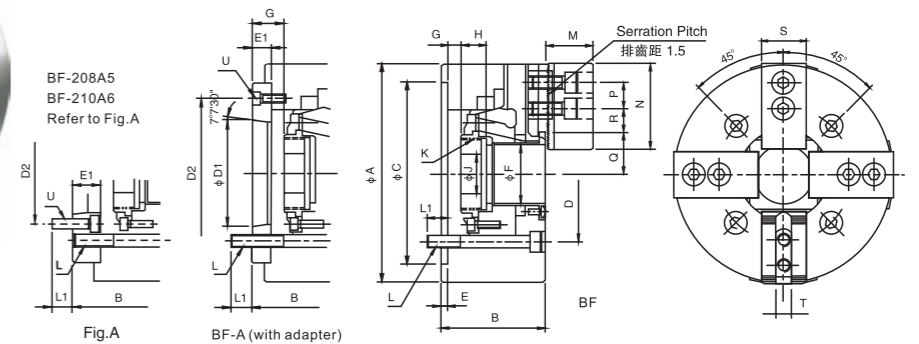

規格 Spec 型號 Model	楔行程(mm) Plunger stroke	爪行程(直徑) Jaw stroke (Dia.) (mm)	夾持直徑 chucking Dia.(mm)		容許油壓缸推力 Max. D.B. Pull (kgf)	最大夾持力 Max clamping force (kgf)	最高回轉速 max r.p.m	慣性矩 kg·m <sup>2</sup>	重量 (kg) Weight	適合油壓缸 Matched cylinders
			最大Max	最小Min						
BF-206 A5	12	5.5	169	15	2700	7000	6000	0.06	11.5 13.3	H-1246/HK-1246
BF-208 A5 A6	16	7.4	210	13	4430	10900	5000	0.19	23.5 25.4	H-1552/HK-1552
BF-210 A6 A8	19	8.8	254	31	5440	14100	4200	0.34	36.3 41	H-1875/HK-1875
BF-212 A8	23	10.6	304	34	7000	18300	3300	0.79	62 65.7	H-2091/HK-2091
BF-215 A11	23	10.6	381	50	9000	22900	2500	2.42	123.7 130.7	H-2511/HK-2511
BF-218 A11	23	10.6	450	50	7240	18355	1500	3.798	140 151	H-2511
BF-224 A20	26	12	610	150	9177	23861	1000	15.2	284 299	ML3320

寸法 Size 型號 Model	A	B	C(H6)	D	D1	D2	E	E1	F	Gmax	Gmin	H	J			
														BF-206 A5	169	81
BF-208 A5 A6	210	91	109 103	170	133.4	82.56 150	104.8 150	5	23 17	52	14.5	37.5 31.5	-1.5	21.5 15.5	20.5	30
BF-210 A6 A8	254	100	120 113	220	171.5	106.38 133.4	133.4	5	25 17	75	8.5	33.5 26.5	-10.5	14.5 7.5	25	45
BF-212 A8	304	110	122					6	18	91	8	26	-15	3	28	50
BF-215 A11	381	133	149	300	235	196.87	260	6	22	117.5	11	33	-12	10	39	60
BF-218 A11	450	133	149	300	235	196.869	260	6	22	117.5	7	29	-16	6	43	-
BF-224 A20	610	147	155	520	463.6	412.775	463.6	6	25	205	16	41	-10	15	38	-

寸法 Size 型號 Model	K max	L	L1	M	N	P	Q max	Q min	R max	R min	S	T	U
BF-206 A5	M55 x 2	4-M10	16	16	37	20	32	29.3	22.8	9.3	31	12	3-M6
BF-208 A5 A6	M60 x 2	4-M12	20	17	38	25	38.7	35	29.8	14.8	35	14	6-M10 3-M6
BF-210 A6 A8	M85 x 2	4-M16	22	24	43	30	51	46.6	33.8	14.3	40	16	6-M12 3-M8
BF-212 A8	M100 x 2		23	25	51		61.3	56	45.8	15.8	50	21	
BF-215 A11	M130 x 2	4-M20	30	28	66	43	82	76.7	46.8	13.8	62	25	4-M10
BF-218 A11	M130x2	4-M20*135	30	28	66	43	82	76.7	79.75	15.25	62	22	3-M10
BF-224 A20	M215x3	8-M24*150	35	35	73	60	139.9	133.9	87.5	24.5	65	25	3-M10

\* 保留技術更改的權利，恕不另行通知 Subject to technology changes without prior information  
\* 非標需求可訂做 Non-standard requirements can be made

## > BB SERIES

### 中空動力夾頭 (三爪大孔徑中空型)



BB-208A5  
BB-210A6  
Refer to Fig. A

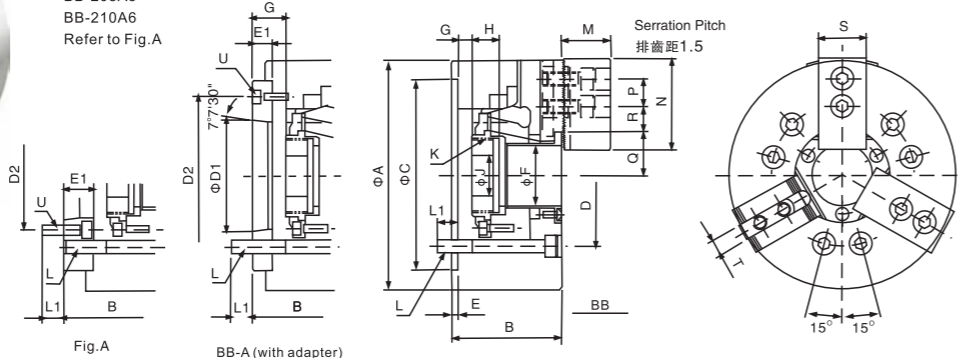

### 3-JAW EXTRA THOUGH HOLE POWER CHUCK

- 楔形三爪超大貫通孔徑。
- 摺動面均經硬化及精密研磨并直接潤滑。
- 高剛性結構及高夾持精度。
- It's a WEDGE-HOOK type 3-jaw with the extra large through-hole.
- Matching surfaces of all parts hardened,ground and lubricated directly
- Construction of high rigidity and high clamping accuracy.

規格 Spec 型號 Model	楔心行程 Plunger stroke (mm)	爪行程(直徑) Jaw stroke (Dia.) (mm)	夾持直徑 chucking Dia.(mm)		容許油壓缸推力 Max.D.B.Pull (kgf)	最大夾持力 Max clamping force (kgf)	最高回轉速 max r.p.m	慣性矩 kg·m <sup>2</sup>	重量 (kg)		適合油壓缸 Matched cylinders
			最大Max	最小Min							
BB-206 A5	12	5.5	170	22	1900	5800	5300	0.06	11	12.8	H-1552/HK-1552
BB-208 A5	16	7.4	210	27	2850	8550	4600	0.15	23	25.5	H-1868/HK-1868
BB-210 A6	19	8.8	254	34	3900	11300	4000	0.32	34	41	H-1878/HK-1878
BB-210 A8	19	8.8	254	34	3900	11300	4000	0.32	34	39.5	H-1878/HK-1878
BB-212 A11	23	10.6	315	47	6000	15600	3500	0.73	51	58	H-2051/HK-2051
BB-215 A15	23	10.6	405	60	7240	18350	2500	2.3	127.4	138.8	HK-2214
BB-218 A15	23	10.6	457	75	7240	18355	2000	4.77	161	172	ML2816

寸法 Size 型號 Model	A	B	C(H6)		D	D1	D2	E	E1	F	Gmax		Gmin		H	J
BB-206 A5	170	81	91	140	104.8	82.56	116	15	52	11	26	-1	14	19	20	
BB-208 A5	210	91	109	170	133.4	104.8		23			37.5	-1.5	21.5		30	
BB-208 A6			103			150	5	17	66	14.5	31.5		15.5	20.5		
BB-210 A6	254	100	120	220	171.5	133.4		25			33.5		14.5		45	
BB-210 A8			113			190		18	78	8.5	26.5	-10.5	7.5	25		
BB-212 A11	315	110	126	300	235	196.8	260	6	33	122	8	30	-15	15	28	50
BB-215 A15	405	133	154	380	330.2	185.78	330.2		22	142	11	38	-12	22	39	60
BB-218 A15	457	133	161	380	330.2	285.775	330.2	6	27	166.5	34	61	11	38	43	-

寸法 Size 型號 Model	K max	L	L1	M	N	P	Q max	Q min	R max	R min	S	T	U	
	BB-206 A5	M60x2	6-M10	16	16	37	73	20	35.5	32.8	20.1	9.3	31	12
BB-208 A5			20	17	38	95	25	45.7	42	23.8	14.3	35	14	6-M10
BB-208 A6	M74x2	6-M12		18										3-M6
BB-210 A6														6-M12
BB-210 A8	M87x2	6-M16	22	24	43	110	30	52	47.6	34.5	12	40	16	3-M8
BB-212 A11	M135x20	6-M20	30	28	51	130	30	74.2	63.5	45.75	15.75	50	25.5	3-M10
BB-215 A15	M155x20	6-M24	35	38	63	165	43	93.5	85.7	43.75	18.25	62	25	3-M12
BB-218 A15	M180x3	6-M24	30	33	66	165	43	96.7	85.2	63.25	18.25	62	22	3-M12

\* 保留技術更改的權利, 恕不另行通知 Subject to technology changes without prior information  
\* 非標準需求可訂做 Non-standard requirements can be made

## > BL SERIES

### 超長爪行程動力夾頭 (三爪高速中空型)



BL-08A5  
BL-10A6  
Refer to Fig. A

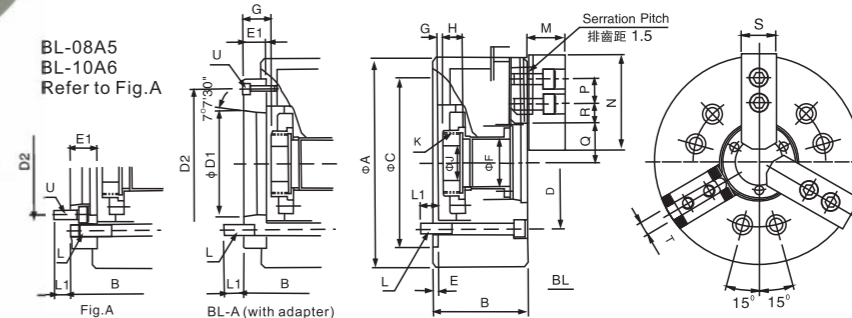

### 3-JAW EXTRA LONG JAW STROKE THOUGH HOLE POWER CHUCK

- 曲柄型三爪超大貫通孔徑, 超長爪行程。
- 摺動面均經硬化及精密研磨, 并直接潤滑。
- 安裝連結方式與中空夾頭一樣, 且可與之相容互換, 不必更改拉杆。
- 高剛性結構及高夾持精度。
- It's a CRANK type 3-jaw with the large through-hole, and extra long jaw stroke.
- Matching surfaces of all parts hardened,ground and lubricated directly.
- Construction of high rigidity and high clamping accuracy.
- The installation is the same as "Through-hole power chuck" and they are replaceable with each other.No need to change the "Draw tube".

規格 Spec 型號 Model	楔心行程 Plunger stroke (mm)	爪行程(直徑) Jaw stroke (Dia.) (mm)	夾持直徑 chucking Dia.(mm)		容許油壓缸推力 Max.D.B.Pull KN(kgf)	最大夾持力 Max clamping force KN(kgf)	最高回轉速 max r.p.m	慣性矩 kg·m <sup>2</sup>	重量 (kg)		適合油壓缸 Matched cylinders
			最大Max	最小Min							
BL-05 A4	12	18	135	6	15.6(1590)	17.2(1750)	4200	0.019	7.2	8.0	H-1036
BL-06 A5	15	24	170	18	23.5(2400)	26.0(2650)	3600	0.063	13	14.8	H-1246
BL-08 A5	20	32	215	25	34.3(3500)	35.0(4150)	3000	0.175	23	25.9	H-1552
BL-08 A6	20	32	215	25	34.3(3500)	35.0(4150)	3000	0.175	23	24.1	H-1552
BL-10 A6	25	37.5	260	47	47.7(4870)	61.0(5700)	2400	0.347	38	45	H-1875
BL-10 A8	25	37.5	260	47	47.7(4870)	61.0(5700)	2400	0.347	38	43.5	H-1875
BL-12 A8	30	45	315	54	64.7(6600)	68.0(7650)	2100	0.827	62	67.5	H-2091
BL-15 A11	35	52	385	50	84.3(8600)	68.0(6930)	1600	2.58	136	143	H-2511

寸法 Size 型號 Model	A	B	C(H6)		D	D1	D2	E	E1	F	Gmax		Gmin		H	J
BL-05 A4	135	65	76	110	82.6	63.51	96	4	15	32	1	16	-11	4	20	12
BL-06 A5	168	84	97	140	104.8	82.56	116		18	42	6.5	24.5	-8.5	9.5	19	20
BL-08 A5			118			104.8			27	48	7	34		14		
BL-08 A6	210	96	114	170	133.4	150			23		30		-13	10	20	30
BL-10 A6			130			133.4	5		25		33		8			
BL-10 A8	254	110	123	220	171.5	190			26	70	8	26	-17	1	25	45
BL-12 A8	304	127	140	220	171.5	139.72			18	91	15	33	-15	3	28	50
BL-15 A11	385	150	166	300	235	196.87	260	6	22	120	12.5	34.5	-22.5	-0.5	39	60

寸法 Size 型號 Model	K max	L	L1	M	N	P	Q max	Q min	R max	R min	S	T	U	
	BL-05 A4	M40x1.5	3-M10	15	15	31	62	14	23	13.75	31	22	25	10
BL-06 A5	M55x2	6-M10	18	15	37	73	20	25.7	13.75	39	27	31	12	3-M6
BL-08 A5			18	19	38	95	25	28.25	16.25	49.25	33.25	35	14	6-M10
BL-08 A6	M60x2	6-M12		20										3-M6
BL-10 A6														6-M12
BL-10 A8	M85x2	6-M16	22	25	43	110	30	35.25	17.25	64.25	45.25	40	16	
BL-12 A8	M100x2		20	19	51	130		46.25	19.25	77	54.5	50	21	6-M8
BL-15 A11	M130x2	6-M20	33	31	63	165	43	51.25	27.25	94.25	68.25	62	25.5	3-M10

\* 保留技術更改的權利, 恕不另行通知 Subject to technology changes without prior information  
\* 非標準需求可訂做 Non-standard requirements can be made

## > BLT SERIES

### 超長爪行程動力夾頭

### 2-JAW EXTRA LONG JAW STROKE THOUGH HOLE POWER CHUCK

- ◎ 曲柄型二爪超大貫通孔徑，超長爪行程。
- ◎ 摺動面均經硬化及精密研磨，并直接潤滑。
- ◎ 高剛性結構及高夾持精度。
- ◎ 安裝連結方式與中空夾頭一樣，且可與之相容互換，不必更改拉杆。
- ◎ It's a CRANK type 2-jaw with the large through-hole, and extra long jaw stroke.
- ◎ Matching surfaces of all parts hardened, ground and lubricated directly.
- ◎ Construction of high rigidity and high clamping accuracy.
- ◎ The installation is the same as "Through-hole power chuck" and they are replaceable with each other. No need to change the "Draw tube".

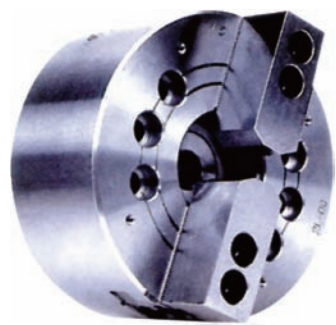

BLT-08A5  
BLT-10A6  
BLT-15A8  
Refer to fig.A

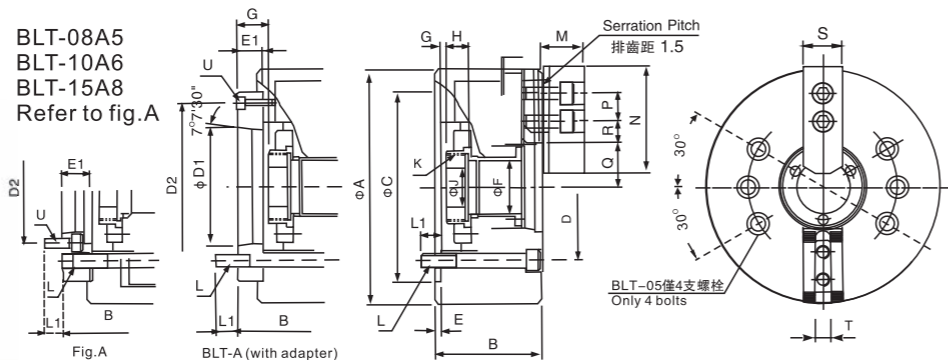

規格 Spec 型號 Model	楔心行程 Plunger stroke (mm)	爪行程(直徑) Jaw stroke (Dia.) (mm)	夾持直徑 chucking Dia.(mm)		容許油壓缸推力 Max.D.B.Pull KN(kgf)	最大夾持力 Max clamping force KN(kgf)	最高回轉速 max r.p.m	慣性矩 kg-m2	重量 (kg)	適合油壓缸 Matched cylinders	最大使用壓力 Max.pressure Mpa(kgf/cm2)
			最大Max	最小Min							
BLT-05 A4	12	18	135	6	10.4 (1060)	11.4(1165)	4200	0.018	6.9 7.7	H-1036	1.6(16)
BLT-06 A5	15	24	168	10	15.7 (1600)	17.2(1760)	3600	0.016	12.6 14.4	H-1246	1.8(18)
BLT-08 A5 A6	20	32	210	10	22.8 (2330)	27(2750)	3000	0.167	22 23.1	H-1552	1.7(17)
BLT-10 A6 A8	25	37.5	254	18	31.8 (3240)	37.2(3800)	2400	0.338	37 44 42.5	H-1875	1.8(18)
BLT-12 A6 A8	30	45	304	30	43.1 (4400)	50(5100)	2100	0.8	60 65.5 147	H-2091	1.9(19)
BLT-15 A11	35	52	381	50	56.2 (5370)	60.6(6180)	1600	2.52	133 140	H-2511	1.7(17)

寸法 Size 型號 Model	A	B	C(H6)	D	D1	D2	E	E1	F	Gmax	Gmin	H	J
BLT-05 A4	135	65	76	110	82.6	63.51	96	4	15	32	1	16	-11
BLT-06 A5	168	84	97	140	104.8	82.56	116	18	42	6.5	24.5	-8.5	9.5
BLT-08 A5 A6	210	96	118 114	170	133.4	104.8	150	27 23	48	7	34 30	-13	14 10
BLT-10 A6 A8	254	110	130 123	220	171.4	106.38	133.4 190	25 18	70	8	33 26	-17	8 1
BLT-12 A6 A8	304	127	140 177	220	171.4	139.72	190	18 33	91	15	33	-15	3
BLT-15 A11	381	150	166	300	235	196.87	260	6 22	120	12.5	45.5 34.5	-22.5	10.5 -0.5

寸法 Size 型號 Model	K max	L	L1	M	N	P	Q max	Q min	R max	R min	S	T	U
BLT-05 A4	M40x1.5	4~M10	15	15	31	62	14	23	13.75	31	22	25	10
BLT-06 A5	M55x2	6~M10	15	15	37	73	20	25.75	16.25	39	27	31	12
BLT-08 A5 A6	M60x2	6~M12	18	17 20	38	95	25	28.25	16.25	49.25	33.25	35	14
BLT-10 A6 A8	M85x2	6~M16	22	18.5 24	43	110	30	35.25	17.25	64.25	45.25	40	16
BLT-12 A6 A8	M100x2	6~M16	20	17 31	51	130	30	46.25	19.25	77	54.5	50	21
BLT-15 A11	M130x2	6~M20	33	30	63	165	43	51.25	27.25	94.25	68.25	62	25.5

\* 保留技術更改的權利，恕不另行通知 Subject to technology changes without prior information  
\* 非標需求可訂做 Non-standard requirements can be made

## > KBL SERIES

### 超大行程三爪卡盤

### SUPER LONG STROKE 3 JAW POWER CHUCK

- ◎ 此為曲柄型卡盤
- ◎ 夾持力大，適用強力車削加工
- ◎ It's crank type chuck
- ◎ The clamping force is very strong, it's applicable for heavy machining process

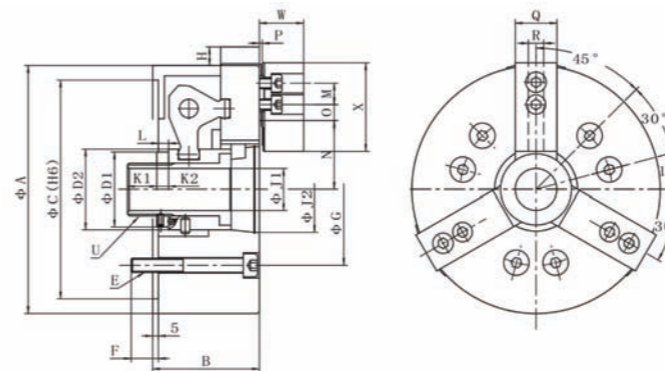

規格 Spec 型號 Model	楔心行程 Plunger stroke (mm)	爪行程(直徑) Jaw stroke (Dia.) (mm)	最大夾持直徑 Max.clamping dia. (mm)	最小夾持直徑 Max.clamping dia. (mm)	最大容許油壓缸推力 Max. D.B. pull KN	最大夾持力 Max clamping force (KN)	最高回轉速 max r.p.m	最高使用壓力 Max Pressure (Mpa)	重量 Weight (kg)	適用油缸 Matching Cylinder
KBL-206	20	32	165	10	22.6	19.6	3600	2.5	11.5	S-100
KBL-208	25	40	210	28	31.4	27.5	3000	2.5	23.6	S-125
KBL-210	28	42	254	42	37.3	34.3	2400	2.8	34.5	S-125
KBL-212	35	50	304	54	49	48	2100	2.8	60.8	S-150

規格 Spec 型號 Model	A	B	C(H7)	D1	D2	E	F	G	H max	J1	J2(H9)	K1
KBL-206	165	80	140	45	54	6-M10	16	104.8	10	21	60	20
KBL-208	215	93	170	65	74	6-M12	20	133.4	11.5	36	80	25
KBL-210	254	111	220	82	96	6-M12	17	171.4	13	55	105	25
KBL-212	304	130	220	92	102	6-M16	22	171.4	15	62	110	30

規格 Spec 型號 Model	K2	L	M	N	O	P	Q	R	T	U	W	X
KBL-206	10	-2--18	20	23.8--39.8	9--30	3	31	12	43	M30*2	37	73
KBL-208	10	-4--21	25	33.8--53.8	10--35	5	35	14	55	M45*2	40	95
KBL-210	12	-2--26	30	46.3--67.3	13.5--37.5	5	40	16	62	M65*2	45	110
KBL-212	14	-3.5--31.5	30	48.3--73.3	14--52	5	50	21	77	M72*2	53	130

\* 保留技術更改的權利，恕不另行通知 Subject to technology changes without prior information  
\* 非標需求可訂做 Non-standard requirements can be made

## > KBLT SERIES

### 超大行程二爪卡盤

### SUPER LONG STROKE 2 JAW POWER CHUCK



- ◎ 此為曲柄型卡盤
- ◎ 夾持力大，適用強力車削加工
- ◎ It's crank type chuck
- ◎ The clamping force is very strong, it's applicable for heavy machining process

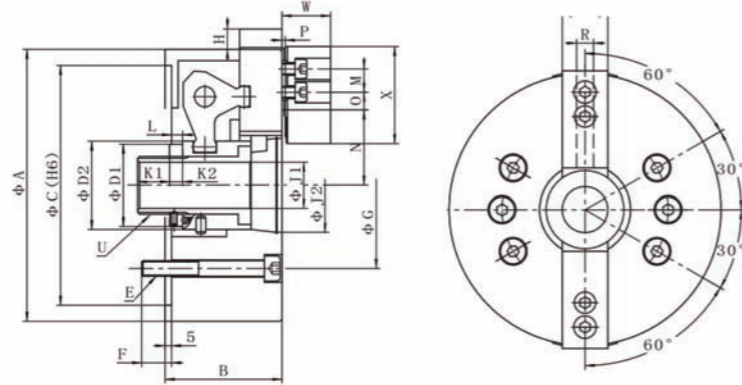

規格 Spec 型號 Model	楔心行程 Plunger stroke (mm)	爪行程(直徑) Jaw stroke (Dia.) (mm)	最大夾持直徑 Max. clamping dia. (mm)	最小夾持直徑 Max. clamping dia. (mm)	最大容許油壓缸推力 Max. D.B. pull KN	最大夾持力 Max clamping force (KN)	最高回轉速 max r.p.m	最高使用壓力 Max Pressure (Mpa)	重量 Weight (kg)	適用油缸 Matching Cylinder
KBLT-206	20	32	165	10	18.1	12.6	3600	1.9	11.8	S-100
KBLT-208	25	40	210	28	20.1	18.5	3000	1.6	23.3	S-125
KBLT-210	28	42	254	42	29.5	26.3	2400	1.9	34	S-125
KBLT-212	35	50	304	54	36	35	2100	1.8	60.2	S-150

規格 Spec 型號 Model	A	B	C(H7)	D1	D2	E	F	G	H Max	J1	J2(H9)	K1
KBLT-206	165	80	140	45	54	6-M10	16	104.8	10	21	60	20
KBLT-208	215	93	170	65	74	6-M12	20	133.4	11.5	36	80	25
KBLT-210	254	111	220	82	96	6-M12	17	171.4	13	55	105	25
KBLT-212	304	130	220	92	102	6-M16	22	171.4	15	62	110	30

規格 Spec 型號 Model	K2	L	M	N	O	P	Q	R	T	U	W	X
KBLT-206	10	-2--18	20	23.8--39.8	9--30	3	31	12	43	M30*2	37	73
KBLT-208	10	-4--21	25	33.8--53.8	10--35	5	35	14	55	M45*2	40	95
KBLT-210	12	-2--26	30	46.3--67.3	13.5--37.5	5	40	16	62	M65*2	45	110
KBLT-212	14	-3.5--31.5	30	48.3--73.3	14--52	5	50	21	77	M72*2	53	130

\* 保留技術更改的權利，恕不另行通知 Subject to technology changes without prior information  
\* 非標需求可訂做 Non-standard requirements can be made

## > T SERIES

### 中實動力夾頭 (三爪高速中實型)

### 3-JAW NON THRU POWER CHUCK

- ◎ 楔形三爪中實夾頭。
- ◎ 折動面均經硬化及精密研磨，并直接潤滑。
- ◎ 高剛性結構及高夾持精度。
- ◎ It's a WEDGE-HOOK type 3-jaw power chuck.
- ◎ Matching surfaces of all parts hardened, ground and lubricated directly.
- ◎ Construction of high rigidity and high clamping accuracy.

T-208A5  
T-210A6  
T-212A6  
Refer to Fig.A

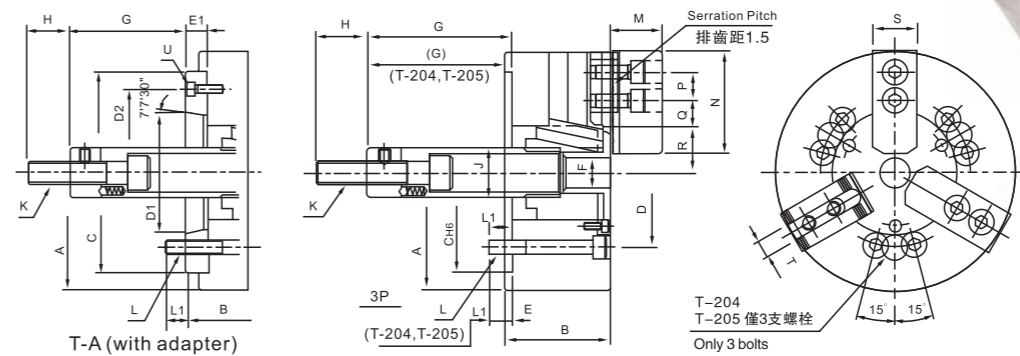
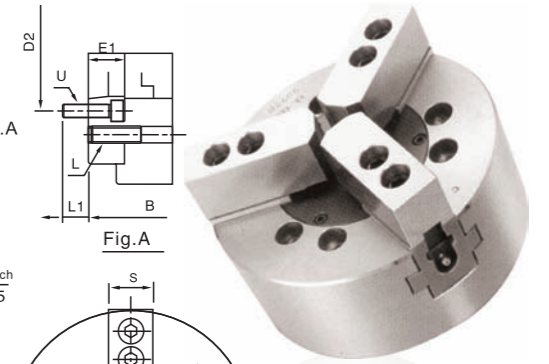

規格 Spec 型號 Model	楔心行程 Plunger stroke (mm)	爪行程(直徑) Jaw stroke (Dia.) (mm)	夾持直徑 chocking Dia.(mm)		容許油壓缸推力 Max. D.B. Pull (kgf)	最大夾持力 Max clamping force (kgf)	最高回轉速 max r.p.m	慣性矩 kg-m2	重量 (kg)		適合油壓缸 Matched cylinders
			最大Max	最小Min							
T-204	15	6.4	110	7	940	1930	8000	0.01	3.8		S-65
T-205 A4			135	12	1190	2440	7000	0.02	6.5	7.3	S-80
T-206 A5	20	8.5	169	15	1470	3870	6000	0.06	11.5	13.3	S-100
T-208 A5	21	8.8	210	13	2360	5840	5000	0.17	21.3	24.2	S-125
T-210 A6										22.4	
T-210 A8	25	8.8	254	31	2900	7540	4200	0.31	33.5	40.5	S-125
T-212 A8	30	10.5	304	34	3740	9780	3300	0.70	59.7	62.7	S-150
T-215 A11	35	16	381	50	4790	12200	2500	2.23	115	122	S-200

寸法 Size 型號 Model	A	B	C(H6)	D	D1	D2	E	E1	F	Gmax.	Gmin.	H	J			
T-204	110	59	85	70.6	-	-	-	-	26	18	3	17.5	-			
T-205 A4	135	60	71	110	82.6	63.51	96	4	33	9	-6	20	-			
T-206 A5	169	81	91	140	104.8	82.56	116	15	45	101.5	86.5	81.5	66.6	19	21	
T-208 A5			109						23		104		83			
T-208 A6	210	91	103	170	133.4	106.38	150	5	17	52	127	110	106	89	20.5	25
T-210 A6			120						25		133		108			
T-210 A8	254	100	113	220	171.5	139.72	190		75	158	140	133	115	25	34	
T-212 A8	304	110	122						91	163	145		115	28	-	
T-215 A11	381	133	149	300	235	196.87	260	6	22	117.5	104	82	69	47	39	-

寸法 Size 型號 Model	K max	L	L1	M	N	P	Q max	Q min	R max	R min.	S	T	U	
T-204	M10x1.5		12	-	24	52	11.3	8.3	23.3	20.1	23		-	
T-205 A4	M12x1.75	3-M8	14	-	31	62	14	6	30.4	27.2	25	10		
T-206 A5	M16x2	6-M10	14	14	37	73	20	18	7.5	37.8	33.5	31	12	
T-208 A5	M20x2.5	6-M12	20		38	95	25	22.3	11.8	46.3	41.9	35	14	
T-208 A6				18										
T-210 A6	M20x2.5				43	110								
T-210 A8	M20x2.5	6-M16	18				30	30.8	11.3	51.1	46.7	40	16	
T-212 A8	M20x2.5		25		51	130		48.8	12.3	61	55.8	50	21	
T-215 A11	M30x2.5	6-M20	30	33	66	165	43	48.8	23.3	77.5	69.5	62	25	4-M10

\* 保留技術更改的權利，恕不另行通知 Subject to technology changes without prior information  
\* 非標需求可訂做 Non-standard requirements can be made

## > TF SERIES

### 三爪中實油壓夾頭

### 2-JAW SOLID POWER CHUCKS

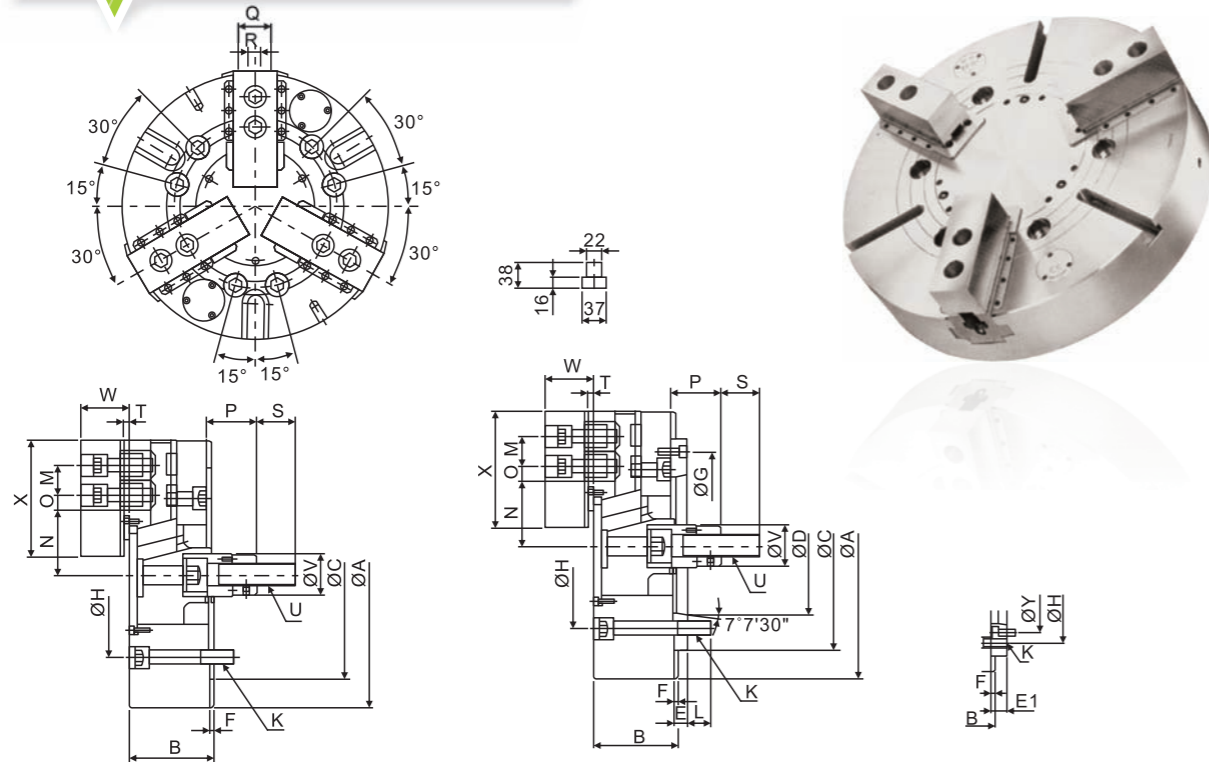

規格 Spec 型號 Model	主軸鼻端番號 Nose of spindle	A	B	C(h6)	D	E	E1	F	G	H	K	L	M
TF-215	A2-11	381	118	300	196.869	22	-	6	260	235	6-M20x2.5P	32	43
TF-218	A2-11	450	118	300	196.869	22	-	6	260	235	6-M20x2.5P	32	43
TF-221	A2-15(A2-11)	530	129	380	285.775	27	41	6	330.2	330.2	6-M24x3P	33	60
TF-224	A2-15(A2-11)	610	129	380	285.775	27	41	6	330.2	330.2	6-M24x3P	33	60
TF-232	A2-15(A2-11)	800	129	380	285.775	27	41	6	330.2	330.2	6-M24x3P	33	60
TF-240	A2-15(A2-11)	1000	129	380	285.775	27	41	6	330.2	330.2	6-M24x3P	33	60

規格 Spec 型號 Model	Nmax	Nmin	Omax	Omin	Pmax	Pmin	Q	R	S	T	U	V	W	X	Y
TF-215	69.05	60.97	58.05	40.05	104	69	62	25.5	55	7	M30x3.5P	60	68	165	-
TF-218	99.46	91.38	58.05	40.05	92	57	62	25.5	55	7	M30x3.5P	60	68	165	-
TF-221	80.49	72.41	101.8	41.8	96.95	61.95	65	25	55	7	M30x3.5P	60	75.5	180	235
TF-224	119.49	111.41	101.8	41.8	96.95	61.95	65	25	55	7	M30x3.5P	60	75.5	180	235
TF-232	119.49	111.39	197.8	41.8	97	61.95	65	25	55	7	M30x3.5P	60	75.5	180	235
TF-240	119.49	111.39	299.8	41.8	97	102	65	25	55	7	M30x3.5P	60	75.5	180	235

規格 Spec 型號 Model	柱塞行程 Plunger stroke (mm)	爪行程 (直徑) Jaw stroke (Diameter) (mm)	最高回轉速 max r.p.m	最大拉力 Max. pull force kgf (KN)	最大靜夾持力 Max. gripping force kgf (KN)	最大設定油壓壓力 Max. hydr. pressure kgf/cm <sup>2</sup> (Mpa)	淨重 (kg) Weight	搭配油壓缸型號 Matching cylinder	夾持範圍 Gripping range (mm)
TF-215	35	16	3000	8260(81)	25290(248)	32(3.1)	104.1	S-200(S-200R)	Ø68~Ø381
TF-218	35	16	2700	8260(81)	25290(248)	32(3.1)	138.5	S-200(S-200R)	Ø100~Ø450
TF-221	35	16	1900	8650(85)	27000(265)	33(3.2)	204.8	S-200(S-200R)	Ø80~Ø530
TF-224	35	16	1700	8650(85)	27000(265)	33(3.2)	260	S-250R	Ø155~Ø610
TF-232	35	16	1100	8650(85)	27000(265)	33(3.2)	455.4	S-250R	Ø155~Ø800
TF-240	35	16	800	8650(85)	27000(265)	33(3.2)		S-250R	Ø155~Ø1000

\* 保留技術更改的權利，恕不另行通知 Subject to technology changes without prior information  
\* 非標需求可訂做 Non-standard requirements can be made

## > TL SERIES

### 二爪中實油壓夾頭

### 2-JAW SOLID POWER CHUCKS

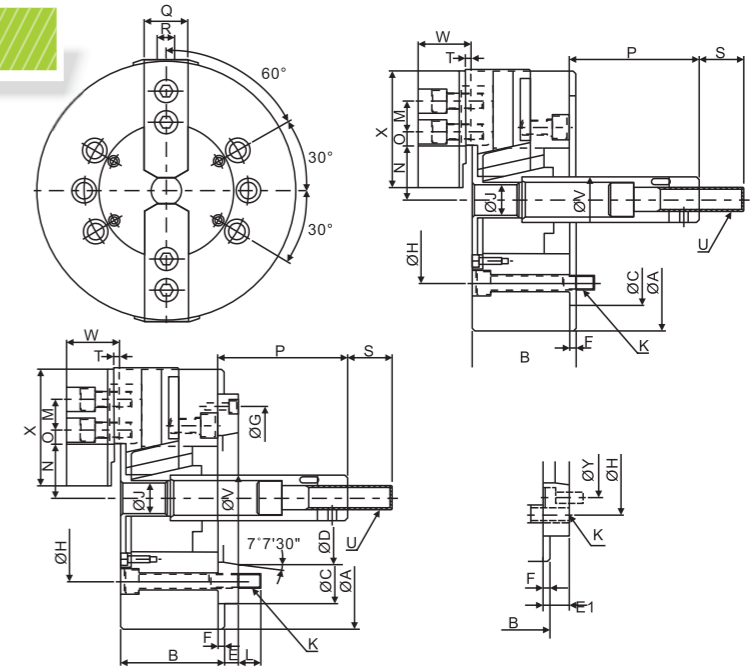
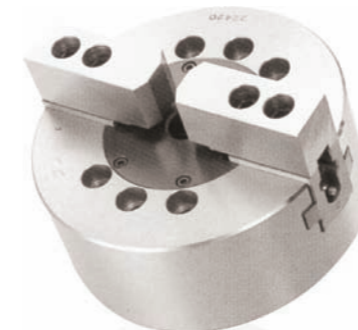

規格 Spec 型號 Model	主軸鼻端番號 Nose of spindle	A	B	C(h6)	D	E	E1	F	G	H	J
TL-204	-	110	52	60	-	-	-	-	-	80	-
TL-205	A2-4	135	55	80	63.513	-	-	7	-	100	-
TL-206	A2-5	165	74	140	82.563	15	-	5	116	104.8	21
TL-208	A2-6(A2-5)	210	85	170	106.375	17	23	5	150	133.4	25
TL-210	A2-8(A2-6)	254	89	220	139.719	18	28	5	190	171.4	34
TL-212	A2-8	304	106	220	139.719	18	-	6	190	171.4	34

規格 Spec 型號 Model	K	L	M	Nmax	Nmin	Omax	Omin	Pmax	Pmin	Q	R	S
TL-204	4-M8x1.25P	12	14	23.3	20.1	11.3	8.3	18	18	23	10	25
TL-205	4-M8x1.25P	14	14	30.4	27.2	13.5	6	9	-6	25	10	35
TL-206	6-M10x1.5P	14	20	37.8	33.25	15.1	9.1	101.5	81.5	31	12	36
TL-208	6-M12x1.75P	18	25	46.3	41.9	22.1	10.1	127	106	35	14	36
TL-210	6-M16x2P	25	30	51.4	47	30.6	9.6	158	133	40	16	36
TL-212	6-M16x2P	25	30	60.7	55.45	48.6	12.6	163	133	50	18	36

規格 Spec 型號 Model	T	U	V	W	X	Y	柱塞行程 Plunger stroke (mm)	爪行程 (直徑) Jaw stroke (Diameter) (mm)	最高回轉速 max r.p.m
TL-204	4	M10x1.5	26	24	52	-	15	6.4	6000
TL-205	4	M12x1.75	28	31	62	-	15	6.4	5500
TL-206	4	M16x2P	34	39	73	116	20	8.5	5000
TL-208	5	M20x2.5P	38	42	95	104.8	21	8.8	4000
TL-210	5	M20x2.5P	45	46	110	133.4	25	8.8	3500
TL-212	5	M20x2.5P	50	54	129	190	30	10.5	3000

規格 Spec 型號 Model	最大拉力 Max. pull force kgf (KN)	最大靜夾持力 Max. gripping force kgf (KN)	最大設定油壓壓力 Max. hydr. pressure kgf/cm <sup>2</sup> (Mpa)	淨重 (kg) Weight	搭配油壓缸型號 Matching cylinder	夾持範圍 Gripping range (mm)
TL-204	540(5.3)	1500(14.7)	15(1.5)	3.8	S-65	Ø5~Ø110
TL-205	540(5.3)	1700(16.7)	15(1.5)	5.8	S-80	Ø14~Ø135
TL-206	1220(12)	3460(34)	17(1.7)	11.1	S-100	Ø9~Ø165
TL-208	1630(16)	4990(49)	16(1.9)	21.3	S-125	Ø12~Ø210
TL-210	1930(19)	7140(70)	19(1.9)	32.6	S-125	Ø15~Ø254
TL-212	2750(27)	10300(101)	20(2.0)	57.0	S-150	Ø20~Ø304

\* 保留技術更改的權利，恕不另行通知 Subject to technology changes without prior information  
\* 非標需求可訂做 Non-standard requirements can be made

## > 4T SERIES

### 中實動力夾頭 (四爪高速中實型)



It's applicable for clamping irregular shape parts

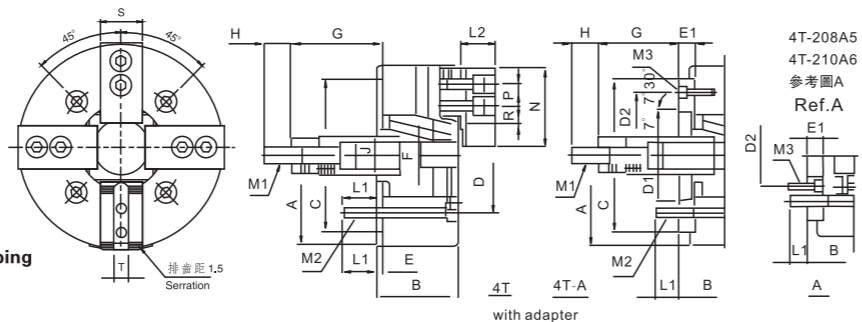

### 4-JAW NON THROUGH HOLE POWER CHUCK

- ◎ 楔形四爪中實卡盤，特別適合异形物的夾持。
- ◎ 摺動面均經硬化及精密研磨，并直接潤滑。
- ◎ 高剛性結構及高夾持精度。
- ◎ It's a wedge four claws solid chuck.
- ◎ Matching surfaces of all parts hardened, ground and lubricated directly.
- ◎ Construction of high rigidity and high clamping accuracy.

規格 Spec. 型號 Model	A	B	C(H6)	D	D1	D2	E	E1	F	G		H	J				
										max	min						
4T-206	A5	165	75	84	140	104.8	82.56	116	5	15	21	101.5	86.5	87.5	66.5	35	34
4T-208	A5	210	85	103	170	133.4	82.56	104.8	5	23	25	127	104	106	83	35	38
4T-208	A6	210	85	97	170	133.4	106.38	150	5	17	25	127	110	106	89	35	38
4T-210	A8	254	89	102	220	171.4	139.72	190	5	18	34	158	140	133	115	35	45
4T-212	A8	304	106	118	220	171.4	139.72	190	6	18	34	163	145	133	115	35	50
4T-215	A11	381	114	130	300	235	196.87	260	6	22	-	104	82	69	47	55	60
4T-218	A11	450	114	130	300	235	196.869	260	6	22	60	92	70	57	35	55	-
4T-224	A15	610	125	146	380	330.2	285.775	330.2	6	27	60	97	70	62	35	55	-
4T-232	A15	810	135	156	380	330.2	285.775	330.2	6	27	60	74	47	39	12	55	-

規格 Spec. 型號 Model	L1	L2	M1	M2	M3	N	P	R		S	T		
								max	min				
4T-206	A5	14	14	39	M16x2	4-M10	4-M6	73	20	18	7.5	31	12
4T-208	A5	20	17	41	M20x2.5	4-M12	6-M10	95	25	22.3	11.8	35	14
4T-208	A6	20	18	41	M20x2.5	4-M12	4-M6	95	25	22.3	11.8	35	14
4T-210	A8	18	25	46	M20x2.5	4-M16	4-M8	110	30	30.8	11.3	40	16
4T-212	A8	22	25	54	M20x2.5	4-M16	4-M8	130	30	48.8	12.3	50	18
4T-215	A11	30	33	63	M30x3.5	4-M20	4-M10	165	43	48.8	23.3	62	25.5
4T-218	A11	-	28	66.5	M30x3.5	4-M20	4-M10	165	43	70.75	24.25	62	25.5
4T-224	A15	-	34	76	M30x3.5	8-M24	4-M12	180	60	93.5	24.5	65	25
4T-232	A15	-	33	97	M30x3.5	8-M24	4-M12	210	80	196.5	25.5	74	25

規格 Spec. 型號 Model	楔心行程 Plunger stroke (mm)	爪行程 (直徑) Jaw stroke(Dia.) (mm)	容許油壓缸推力 Max.D.B.pull KN(kgf)	最大夾持力 Max. clamping force KN(kgf)	最高回轉速 Max. r.p.m	夾持直徑 Chucking Dia. (mm)	慣量 I kg-m2	重量 (kg) Weight (kg)	適用油壓缸 Matching cyl	最大使用壓力 Max.pressure Mpa(kgf/cm2)
4T-206	A5	20	17.9(1830)	52.4(5350)	5250	14-165	0.05	13 14	S-100	2.5(25)
4T-208	A5	21	25(2550)	74.5(7600)	4750	17-210	0.14	24 28	S-125	2.3(23)
4T-208	A6	21	25(2550)	74.5(7600)	4750	17-210	0.14	24 27	S-125	2.3(23)
4T-210	A8	25	28.9(2950)	107.8(11000)	4000	22-254	0.3	35 40	S-125	2.6(26)
4T-212	A8	30	41(4180)	155.8(15900)	3360	22-304	0.73	59 63	S-150	2.6(26)
4T-215	A11	35	82(8360)	248.4(25350)	3000	50-371	1.95	100 107	S-200	3.2(32)
4T-218	A11	35	96(9687)	248.4(25350)	2000	78-450	3.505	134 140.2	S-200	3.2(32)
4T-224	A15	35	82(8360)	273(27838)	1520	152-610	7.812	235 244	S-200	3.2(32)
4T-232	A15	35	82(8360)	215(21924)	920	100-810	31.2	400 416	S-200	3.2(32)

\* 保留技術更改的權利，恕不另行通知 Subject to technology changes without prior information  
\* 非標需求可訂做 Non-standard requirements can be made

## > 3M SERIES

### 中實長爪行程夾頭



### LONG JAW STROKE POWER CHUCK

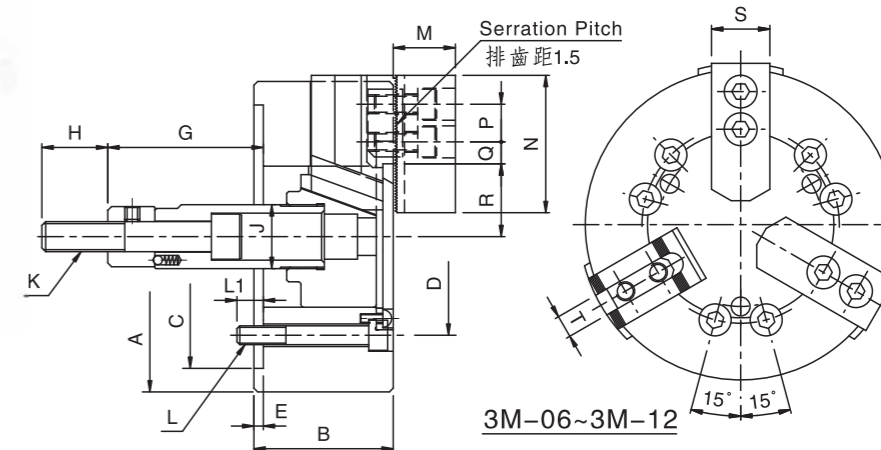
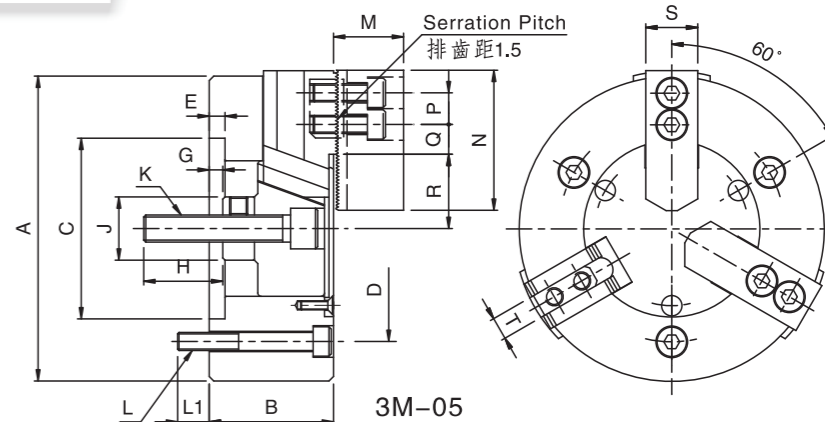

- ◎ It's a WEDGE-HOOK type 3-jaw power chuck, and extra long jaw stroke.
- ◎ Matching surfaces of all parts hardened, ground and lubricated directly.
- ◎ Construction of high rigidity and high clamping accuracy

規格 Spec. 型號 Model	楔心行程 Plunger stroke (mm)	爪行程 (直徑) Jaw stroke(Dia.) (mm)	夾持直徑 chucking Dia.(mm)		容許油壓缸推力 Max.D.B.pull KN(kgf)	最大夾持力 Max clamping force (kgf)	最高回轉速 max r.p.m	慣性矩 kg-m2	重量 (kg) Weight	適用油壓缸 Matching cyl	最大使用壓力 Max.pressure Mpa(kgf/cm2)
			最大Max	最小Min							
3M-05	15	10.9	135	14	9.8(1000)	16.4(1670)	4500	0.02	6.0	SNK-75	2.7(27)
3M-06	20	14.5	165	14	21.6(2200)	36(3680)	4000	0.04	12.2	SNK-100	3.0(30)
3M-08	23	16.7	210	17	29.4(3000)	54.9(5600)	3500	0.13	23.0	SNK-125	2.9(29)
3M-10	27	19.6	254	22	39.2(4000)	74(7550)	3000	0.30	34.3	SNK-150	2.8(28)
3M-12	30	21.8	304	26	54(5500)	99(10100)	2500	0.71	59.4	SNK-150	3.6(36)

寸法 Size 型號 Model	A	B	C(H6)	D	E	Gmax	Gmin	H	J
3M-05	135	55	80	100	7	6	-9	35	28
3M-06	165	74	140	104.8		101.5	81.5		34
3M-08	210	85	170	133.4	5	129	106	36	38
3M-10	254	89	220	171.4		160	133		45
3M-12	304	106			6	70	40	46	50

寸法 Size 型號 Model	K	L	L1	M	N	P	Q max	Q min	R max	R min	S	T
3M-05	M12X1.75	3-M8	14	31	62	14	17.0	5.5	32.9	27.45	25	10
3M-06	M16X2	6-M10		37	73	20	17.6	7.0	38.7	31.4	31	12
3M-08		6-M12	20	38	95	25	22.8	8.8	47.5	39.1	35	14
3M-10	M20X2.5			43	110	30	33.0	12.8	53.9	44.1	40	16
3M-12	M24X3	6-M16	18	51	130	30	47.8	13.3	62.5	51.6	50	21

\* 保留技術更改的權利，恕不另行通知 Subject to technology changes without prior information  
\* 非標需求可訂做 Non-standard requirements can be made

### > 2M SERIES

#### 中實長爪行程夾頭

#### LONG JAW STROKE POWER CHUCK

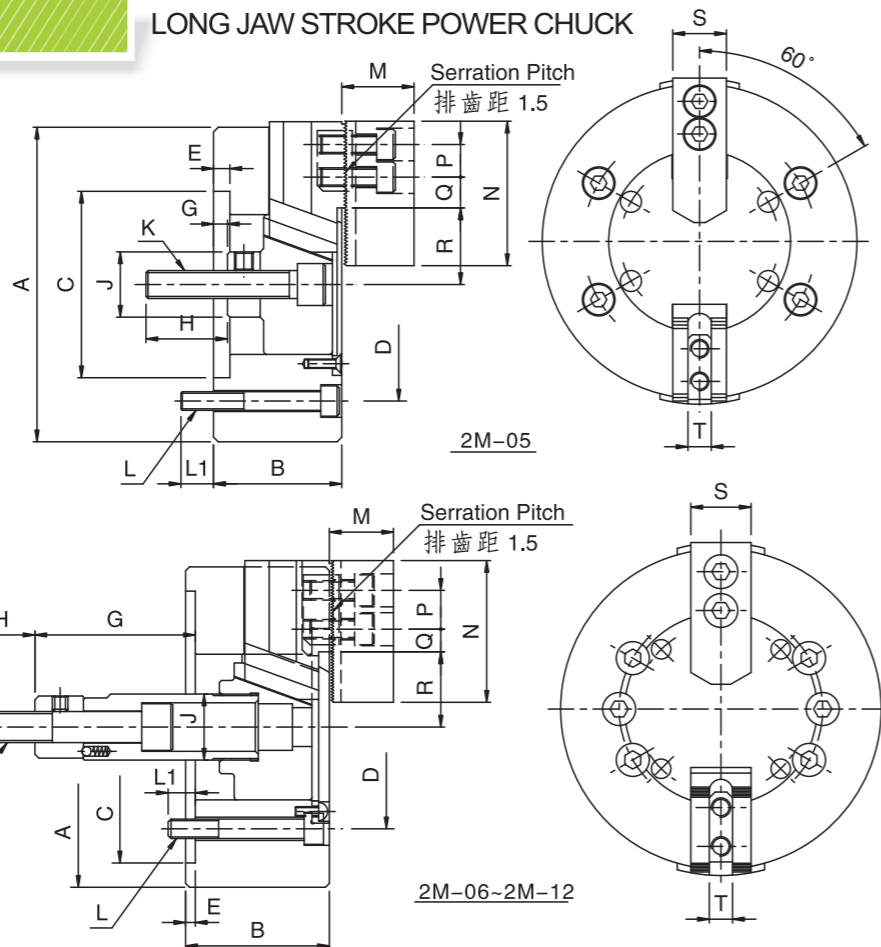

- It's a WEDGE-HOOK type 2-jaw power chuck, and extra long jaw stroke.
- Matching surfaces of all parts hardened, ground and lubricated directly.
- Construction of high rigidity and high clamping accuracy

規格 Spec 型號 Model	楔心行程 Plunger stroke (mm)	爪行程(直徑) Jaw stroke (Dia.) (mm)	夾持直徑 chucking Dia.(mm)		容許油壓缸推力 Max.D.B.pull KN(kgf)	最大夾持力 Max clamping force (kgf)	最高回轉速 max r.p.m	慣性矩 kg·m <sup>2</sup>	重量 (kg) Weight	適用油壓缸 Matching Cyl.	最大使用壓力 Max. pressure Mpa(kgf/cm <sup>2</sup> )
			最大Max	最小Min							
2M-05	15	10.9	135	14	6.5(660)	11(1120)	4500	0.02	6.0	SNK-75	1.8(18)
2M-06	20	14.5	165	14	14.3(1460)	24(2450)	4000	0.04	12.2	SNK-100	2.0(20)
2M-08	23	16.7	210	17	19.6(2000)	36.6(3730)	3500	0.13	23.0	SNK-125	1.9(19.3)
2M-10	27	19.6	254	22	26.1(2660)	49.3(5030)	3000	0.30	34.3	SNK-125	1.8(18.6)
2M-12	30	21.8	304	26	36(3670)	66(6730)	2500	0.71	59.1	SNK-150	2.4(24)

寸法 Size 型號 Model	A	B	C(H6)	D	E	Gmax	Gmin	H	J
2M-05	135	55	80	100	7	6	-9	35	28
2M-06	165	74	140	104.8	5	101.5	81.5	36	34
2M-08	210	85	170	133.4	5	129	106	36	38
2M-10	254	89	220	171.4	5	160	133	36	45
2M-12	304	106	220	171.4	6	70	40	46	50

寸法 Size 型號 Model	K	L	L1	M	N	P	Q max	Q min	R max	R min	S	T
2M-05	M12X1.75	3-M8	14	31	62	14	17.0	5.5	32.9	27.45	25	10
2M-06	M16X2	6-M10	14	37	73	20	17.6	7.0	38.7	31.4	31	12
2M-08	M20X2.5	6-M12	20	38	95	25	22.8	8.8	47.5	39.1	35	14
2M-10	M20X2.5	6-M16	18	43	110	30	33.0	12.8	53.9	44.1	40	16
2M-12	M24X3	6-M16	18	51	130	30	47.8	13.3	62.5	51.6	50	21

\* 保留技術更改的權利，恕不另行通知 Subject to technology changes without prior information  
\* 非標需求可訂做 Non-standard requirements can be made

### > PL SERIES

#### 後拉式油壓夾頭

#### PULL BACK POWER CHUCKS

後拉式油壓夾頭作徑向夾持同時強力後拉，工件不會上浮，適用於鑄件及鍛件的加工。

- 後拉式夾持將工件緊貼在基準面上，使夾持穩固，適于重切削。
- 圓柱滑動結構，可長期使用，並確保重複夾持的優異精度。
- 準確的自定中心及強力夾持工件不上浮特性，要求長度精準的加工最適宜。
- 可採用到位偵測，配合自動化系統。

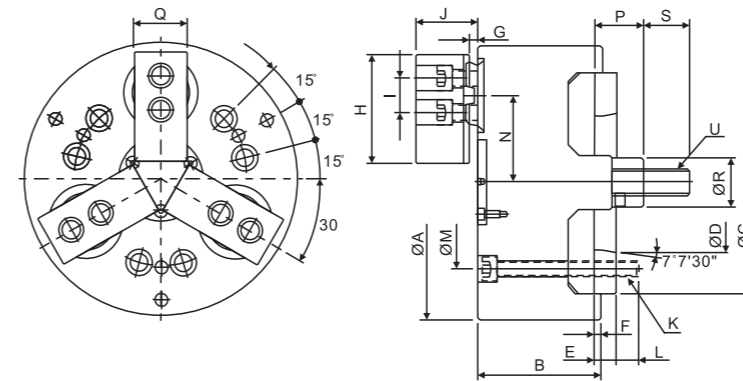

Pull back feature of radial gripping will lead to almost no work piece uplifting displacement; OMATEI Pull Back Power Chucks are ideal for machining casting and forging parts;

- By appressing the gripped work piece to the surface, OMATEI Pull Back Power Chucks are suitable for heavy machining.
- Chuck Actuators with cylindrical structure are durable and ensures high gripping repeatability.
- Accurate self-centering and pull back features are adequate for precise length control machining requirements.
- Optional components can be selected for detecting the right position on an automated loading machine.

規格 Spec 型號 Model	A	B	C	D	E	F	Gmax	Gmin	H	Jmax	Jmin
PL-06	169	83	140	82.563	15	5	15	5	70	46	36
PL-08	210	97	170	106.375	17	5	16.5	6.5	84	57	47
PL-10	254	110	220	139.719	18	5	22	6	100	68	52
PL-12	304	125	220	139.719	18	5	21.5	5.5	120	72.5	56.5

規格 Spec 型號 Model	I	K	L	M	Nmax	Nmin	Pmax	Pmin	Q	R
PL-06	-	6-M10x1.5P	14	104.8	56.65	54	33	23	35	32
PL-08	26	6-M12x1.75P	17	133.4	69.65	67	38	28	40	38
PL-10	32	6-M16x2P	24	171.4	87.8	82	48	32	50	50
PL-12	36	6-M16x2P	20	171.4	102.8	97	47	31	60	52

規格 Spec 型號 Model	S	U	柱塞行程 Plunger stroke (mm)	爪行程 (直徑) Jaw stroke (Diameter) (mm)	最高回轉速 max r.p.m	最大拉力 Max. pull force kgf (KN)
PL-06	36	M16x2P	10	5.3	3500	1420(14)
PL-08	36	M20x2.5P	10	5.3	3000	2240(22)
PL-10	46	M24x3P	16	11.6	2500	3160(31)
PL-12	50	M27x3P	16	11.6	2000	4480(44)

規格 Spec 型號 Model	最大靜夾持力 Max. gripping force kgf (KN)	最大設定油壓壓力 Max. hydr. pressure kgf/cm <sup>2</sup> (Mpa)	淨重 (kg) Weight	搭配油壓缸型號 Matching cylinder	夾持範圍 Gripping range (mm)
PL-06	2950(29)	22(2.2)	15.4	S-100(S-100R)	Ø35-Ø160
PL-08	4890(48)	22(2.2)	27.8	S-125(S-125R)	Ø40-Ø210
PL-10	4990(49)	30(2.9)	45.9	S-125(S-125R)	Ø50-Ø254
PL-12	7240(71)	30(2.9)	75.7	S-150(S-150R)	Ø50-Ø304

\* 保留技術更改的權利，恕不另行通知 Subject to technology changes without prior information  
\* 非標需求可訂做 Non-standard requirements can be made



### > 2SL SERIES

#### 2SL斜拉式動力卡盤

#### 2 SL JAW PULL LOCK POWER CHUCK

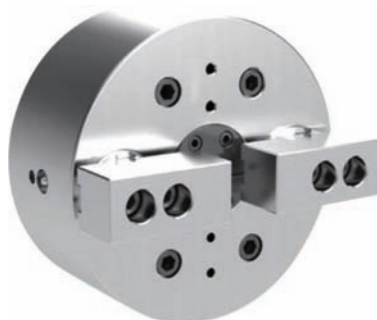

- ◎ 採用斜柱後拉式結構，精度高，夾緊力大。
- ◎ 卡盤工作時，由斜柱的後拉將工件拉向定位面再進行夾緊，從而保證了徑向尺寸和軸向尺寸的精度。
- ◎ 本卡盤適合於夾持異型工件，尤其是對垂直度和平行度有要求的工件。  
注：此型卡盤祇能做外徑夾持，夾持尺寸變換時，須更換軟爪爪。
- ◎ It's adopted the structure of slanting post with pulling back type, high precision, strong clamping force.
- ◎ The slanting post of the chuck pull the workpiece back to position place, and then clamping it, therefore, the chuck can ensure the accuracy of radial size and axial size.
- ◎ This chuck is applicable for clamping the special shape workpiece, especially, it's applicable for the workpiece which need high precision requirements on squareness and parallelism.  
Re: This chuck is only for clamping out diameter, the soft jaws need changing when the clamping size is changed.

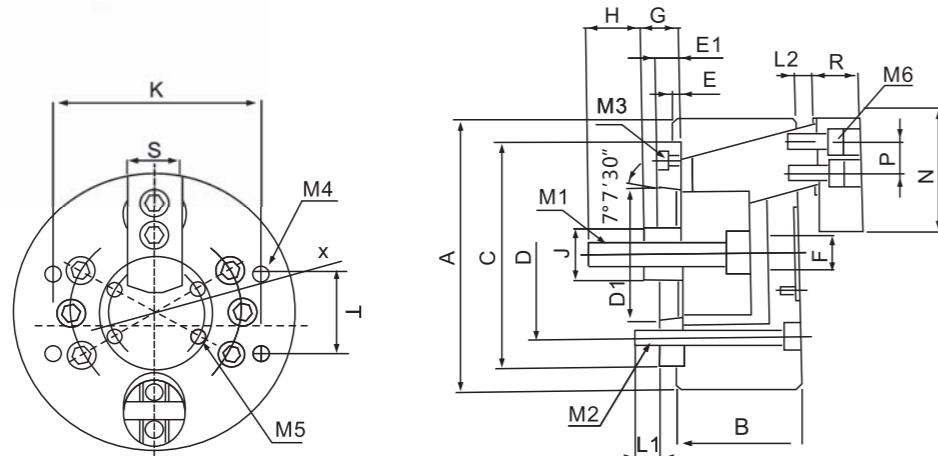

型號 Model	連接盤 Adapter	A	B	C (H6)	D	D1	E	E1	F	G max	G min	H	J	K	L1	L2 Min
2SL-05	A4	130	70	110	82.6	63.51	5	15	20	20	8	30	28	100	12	7
2SL-06	A5	165	80	140	104.8	82.56	5	15	30	30	10	35	32	132	13	8
2SL-08	A5	210	85	170	133.4	82.56	5	17	40	30	10	40	37	160	17	9
2SL-08	A6	210	85	170	133.4	106.38	5	23	40	30	10	40	37	160	17	9

型號 Model	連接盤 Adapter	M1	M2	M3	M4	M5	M6	N	P	R	S	T	X
2SL-05	A4	M12	4-M10	4-M16	4-M10	4-M4	4-M8	60	16	30	30	40	35
2SL-06	A5	M16	6-M10	4-M16	4-M10	4-M5	4-M10	73	23	35	35	48	45
2SL-08	A5	M20	6-M12	4-M16	4-M10	4-M6	4-M12	82	26	40	40	60	55
2SL-08	A6	M20	6-M12	4-M16	4-M10	4-M6	4-M12	82	26	40	40	60	55

型號 Model	連接盤 Adapter	楔心行程 Plunger stroke (mm)	爪行程(直徑) Jaw stroke (Dia.) (mm)	許用推拉力 Max DB Pull force KN(kgf)	最大夾緊力 Max clamping force KN(kgf)	最高回轉速 max r.p.m	夾持範圍 Gripping range (mm)	慣性矩 kg·m <sup>2</sup>	重量 (Kg) Weight
2SL-05	A4	12	6.2	7.9(800)	13.4(1400)	4000	6-80	0.06	7
2SL-06	A5	20	10.3	11.8(1200)	20.6(2100)	3500	15-100	0.19	13.5
2SL-08	A5	20	10.3	17.6(1800)	31.4(3200)	3000	40-160	0.57	24.5
2SL-08	A6	20	10.3	17.6(1800)	31.4(3200)	3000	40-160	0.57	25.5

\* 保留技術更改的權利，恕不另行通知 Subject to technology changes without prior information  
\* 非標準需求可訂做 Non-standard requirements can be made

### > 3A SERIES

#### 後拉固鎖式動力夾頭

#### PULL LOCK POWER CHUCK



- ◎ 銷柱後拉型三爪中空夾頭。
- ◎ 高夾持力高精度。
- ◎ 適合使用於重切削的場合。
- ◎ It's a Pin-Arbor Draw Down type 3-jaw thru-hole power chuck.
- ◎ High radial gripping force and high accuracy.
- ◎ Suitable for heavy machining.

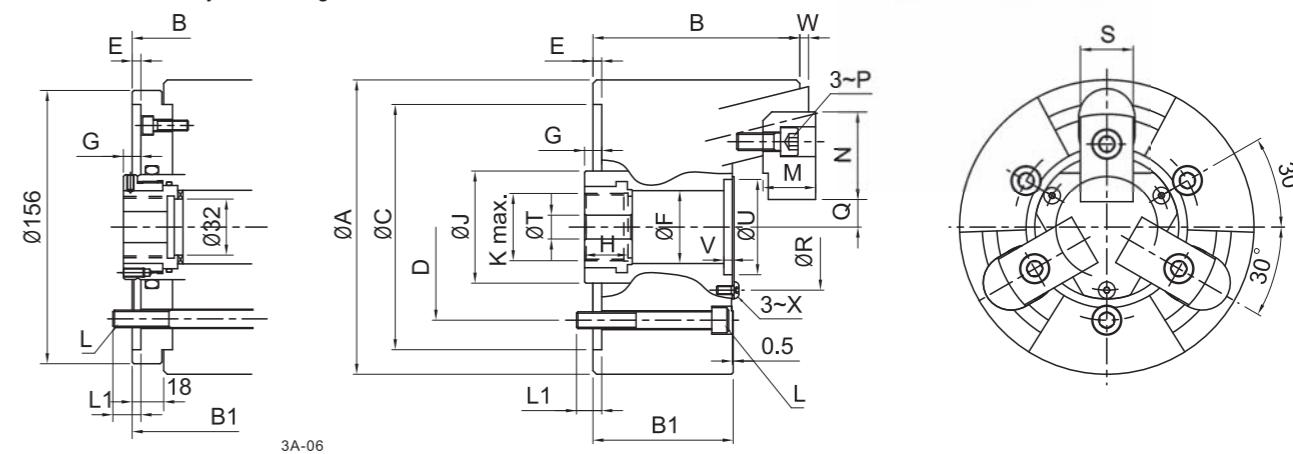

規格 Spec 型號 Model	楔心行程 Plunger stroke (mm)	爪行程(直徑) Jaw stroke (Dia.) (mm)	夾持直徑 chucking Dia.(mm) 最大Max	最小Min	容許油壓缸推力 Max.D.B.pull KN(kgf)	最大夾持力 Max clamping force (kgf)	最高回轉速 max r.p.m	慣性矩 kg·m <sup>2</sup>	重量 (Kg) Weight	適用油壓缸 Matching Cyl	最大使用壓力 Max.pressure Mpa(kgf/cm <sup>2</sup> )
3A-203	4	2	42	14	5.8(590)	16.7(1700)	10000	0.001	1.8	SNK-75	1.6(16)
3A-204	6	3	60	10	10.0(1020)	28.4(2900)	8000	0.005	3.9	SNK-75	2.7(27)
3A-205			84	15	13.9(1420)	39.7(4050)					
3A-206	105	20	17.9(1830)	57.8(5900)	7000	0.055	14.7	SNK-100	2.6(26)		
3A-208	10	5	132	25	25.0(2550)	80.0(8150)	6000	0.14	25.5	SNK-125	2.2(22)
3A-210			163	34	35.0(3570)	100.0(10100)	4500	0.36	43.5	SNK-125	3.1(3.1)
3A-212			210	81	35.0(3570)	100.0(10100)	3600	0.68	63.0	SNK-125	3.1(3.1)

寸法Size 型號 Model	A	B	B1	C(H6)	D	E	F	G max	G min	H	J	K	L	L1
3A-203	85	54.5	42	70	54	3.5	25	18	14	22	38	M20X1.5	3-M8	11
3A-204	110	72.5	55	85	70.6	4	30	16	10	24.5	42	M24X1.5	3-M10	12
3A-205	135	84.5	63	110	82.6		35	20	10	26	50	M28X1.5	3-M10	15
3A-206	168	121	83	140	104.8	5	42	20	10	25	60	M35X1.5	6-M10	16
3A-208	210	137	92	170	133.4		52	21	11	31	80	M48X2	3-M12	18
3A-210	254	152	102	220	171.4	75	25	15	37	105	135	M68X2	3-M16	23
3A-212	304	157												

寸法 Size 型號 Model	M	N	P	Q max	Q min	R	S	T	U(H6)	V	W max	W min	X
3A-203	12	26	M5	7.5	6.5	38	15	10	32	3.5	2	-2	M3
3A-204	17	32	M6	10.75	9.25	46	20		38	4	3	-3	M4
3A-205	20	41.5	M8	13.25	11.75	55	24	45	5	5	3	-3	M5
3A-206	30	50	M10	15.75	13.25	72	30	17	58	6	5	-5	M6
3A-208	34	63	M12	16.25	13.75	82	35		68				
3A-210	39	74	M14	20.75	18.25	107	40	93	114	6	5	-5	M8
3A-212	44			44.25	41.75	130		114					

\* 保留技術更改的權利，恕不另行通知 Subject to technology changes without prior information  
\* 非標準需求可訂做 Non-standard requirements can be made

## > 3A-K SERIES

### 後拉固鎖式動力夾頭

#### PULL LOCK POWER CHUCK

- ◎ 銷柱後拉型三爪夾頭。
- ◎ 高夾持力高精度。
- ◎ 適合使用於重切削の場合。
- ◎ It's a Pin-Arbor Draw Down type 3-jaw thru-hole power chuck.
- ◎ High radial gripping force and high accuracy.
- ◎ Suitable for heavy machining.

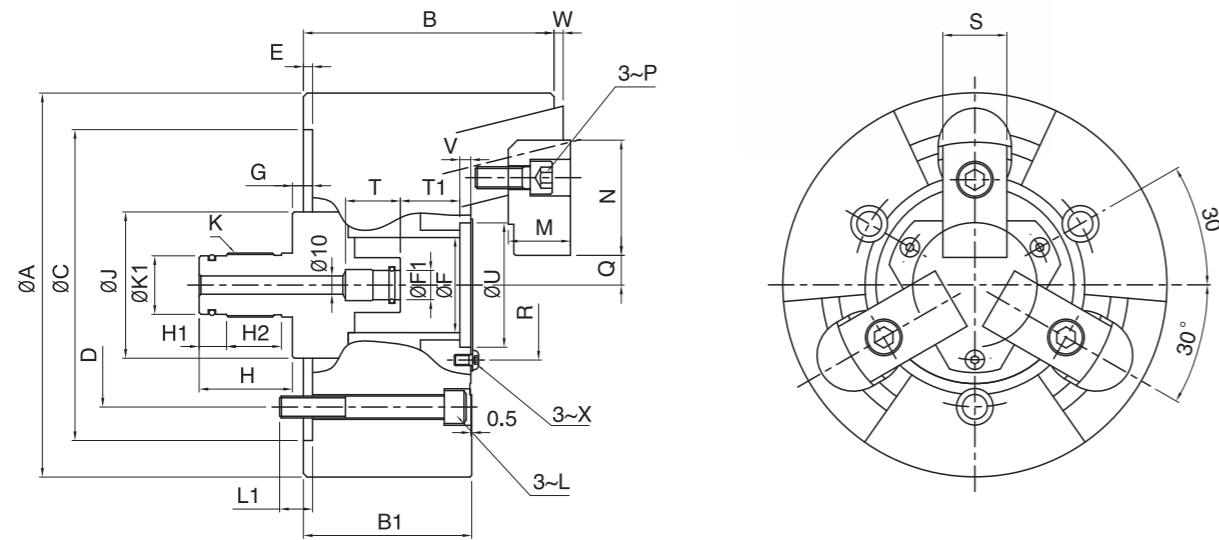

規格 Spec 型號 Model	楔心行程 Plunger stroke (mm)	爪行程(直徑) Jaw stroke (Dia.) (mm)	夾持直徑 chucking Dia.(mm)		容許油壓缸推力 Max.D.B.pull KN(kgf)	最大夾持力 Max clamping force (kgf)	最高回轉速 max r.p.m	慣性矩 kg·m <sup>2</sup>	重量 (Kg) Weight	適用油壓缸 Matching Cyl	最大使用壓力 Max.pressure Mpa(kgf/cm <sup>2</sup> )
			最大Max	最小Min							
3A-205K	6	3	84	15	13.9(1420)	39.7(4050)	8000	0.018	6.8	SLN-100 SLAN-100	2.0(20)
3A-206K			105	24	18.0(1835)	58.0(5910)	7000	0.055	14.9		2.5(25)
3A-208K	10	5	132	25	25.0(2550)	80.0(8150)	6000	0.14	25.8	SLN-125 SLAN-125	2.2(22)
3A-210K			163	34	35.0(3570)	100.0(10100)	4500	0.36	44.0		
3A-212K			210	81			3600	0.68	63.8		

寸法 Size 型號 Model	A	B	B1	C(H6)	D	E	F	F1(h8)	G max	G min	H	H1	H2	J	K	K1	L1
3A-205K	135	84.5	63	110	82.6	4	35	14	16	10	42	12	-	50	M25X1.5	22	M10
3A-206K	168	118	80	140	104.8		45		20		48			60	M28X1.5	26	
3A-208K	210	137	92	170	133.4		52		21	11	51		30	80	M35X1.5	32	M12
3A-210K	254	152	102	220	171.4	5	75	16	25		51	15		105	M38X1.5	35	M16
3A-212K	304	157					100		25	15	51			135	M45X1.5	42	

寸法 Size 型號 Model	L1	M	N	P	Q max	Q min	R	S	T	T1	U(H6)	V	W max	W min	X
3A-205K	15	20	41.5	M8	13.25	11.75	55	24	25	15.5	45	5	3	-3	M5
3A-206K	16.5	30	50	M10	15.75	13.25	72	30		26.5	58				
3A-208K	18	34	63	M12	16.25	13.75	82	35	30	32.5	68	6	5	-5	M6
3A-210K	23	39	74	M14	20.75	18.25	107			36.5	93				M8
3A-212K	26	44	74	M14	44.25	41.75	130	40			114				M10

\* 保留技術更改的權利，恕不另行通知 Subject to technology changes without prior information  
\* 非標需求可訂做 Non-standard requirements can be made

## > 3E SERIES

### 三爪中實型內張後拉式動力夾頭

#### EXPANSIBLE PULL LOCK POWER CHUCK

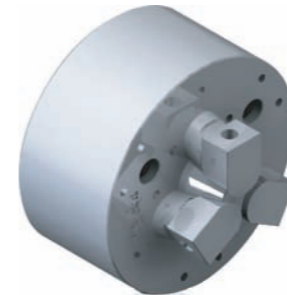

- ◎ 內張後拉式動力夾頭
- ◎ 適用於內徑夾持。
- ◎ 可同時將工件做徑向夾持與軸向後拉，使工件不上浮并緊貼座金基準面。
- ◎ 高精度安定性，適合最後制程加工。
- ◎ 氣密檢知(選配)。
- ◎ Expansible Pull Lock Power Chuck
- ◎ Suitable for internal gripping
- ◎ Radial clamp and axial pull down at the same time, keep the workpiece attaching close to the base surface of the chuck.
- ◎ Almost no workpiece uplifting displacement.
- ◎ With high precision and stability that chuck suitable for end process..
- ◎ Air-tight pressure detect function is optional.

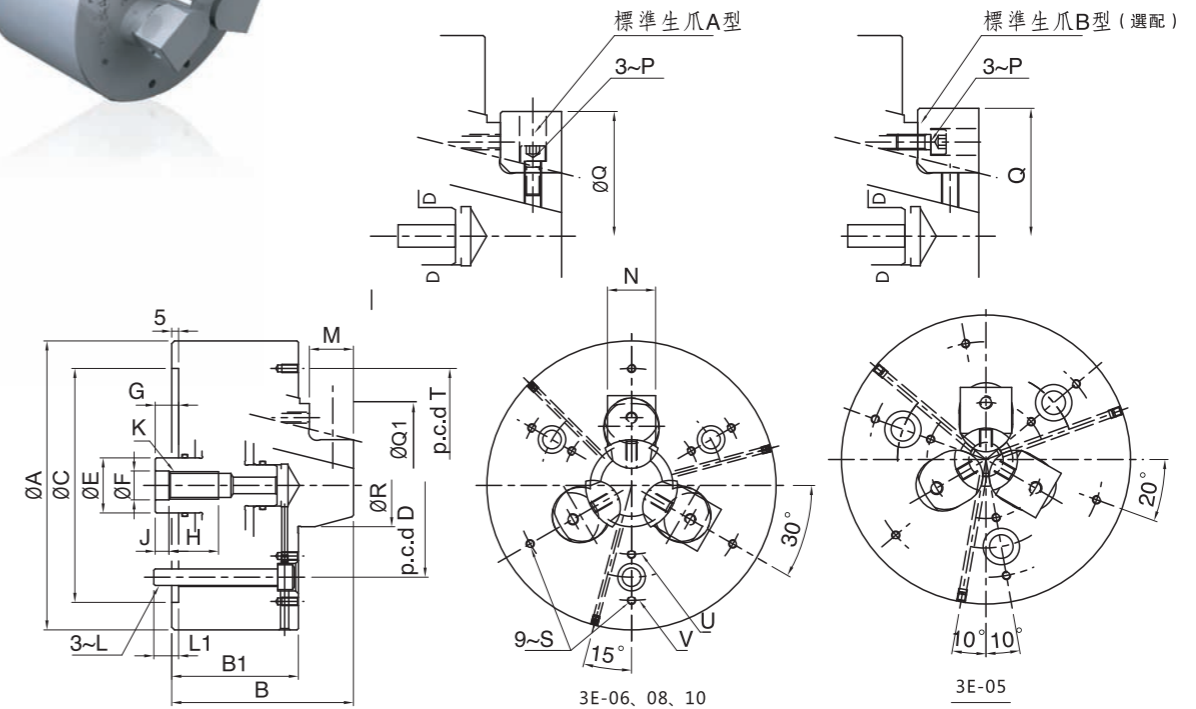

型號 Model	楔心行程 Plunger stroke (mm)	爪行程(直徑) Jaw stroke (Dia.) (mm)	最大夾持直徑 Chucking Dia. Max (mm)	最小夾持直徑 Chucking Dia. Min (mm)	容許油壓缸推力 Max.D.B.pull KN(kgf)	最大夾持力 Max clamping force (kgf)	最高回轉速 max r.p.m	慣性矩 kg·m <sup>2</sup>	重量 (kg) Weight	適用回轉缸 Matching cyl.	最大使用壓力 Max.pressure Mpa (kgf/cm <sup>2</sup> )
3E-05	6	3	83	29	13.0(1325)	42.0(4280)	7000	0.018	7.2	S-100R	1.8(18.5)
3E-06	10	5	110	44	18.0(1835)	58.0(5910)	6000	0.042	13.6	S-100R	2.5(25.6)
3E-08	10	5	150	50	25.0(2530)	80.0(8150)	5000	0.14	26.5	S-125R	2.2(22.5)

型號 Model	A	B	B1	C(H6)	D	E	F(H8)	G max	G min	H	J	K	L	L1
3E-05	135	98	72	110	82.6	25	18	18	12	25	8	M16	M10	15
3E-06	165	112	80	140	104.8	35	18	22	12	30	8	M16	M10	16
3E-08	210	132	90	170	133.4	40	21	22	12	36	10	M20	M12	18

型號 Model	M	N	P	Type A (Q max)	Type A (Q min)	Type B(Q max)	Type B(Q min)	Q1(Q max)	Q1(Q min)	R	S	T	U	V
3E-05	20	25	M6	68	50	83	67	50	29	25	M6X12	110	55	110
3E-06	23	31	M6	90	70	110	89	70	44	40	M6X12	130	76	134
3E-08	30	35	M6	110	90	150	108	90	50	49	M6X12	170	100	170

\* 保留技術更改的權利，恕不另行通知 Subject to technology changes without prior information  
\* 非標需求可訂做 Non-standard requirements can be made

## ➤ 1L SERIES

### 單爪中實型超長爪行程動力夾頭

### EXTRA LONG JAW STROKE POWER CHUCK



- ◎ 曲柄型單爪大貫通孔徑，超長爪行程。
- ◎ 適用於治具的夾持。
- ◎ 高剛性結構及高夾持精度。
- ◎ It's a CRANK type single-jaw with the large through-hole, and extra long jaw stroke.
- ◎ Suitable for clamping the jig.
- ◎ Construction of high rigidity and high clamping accuracy.

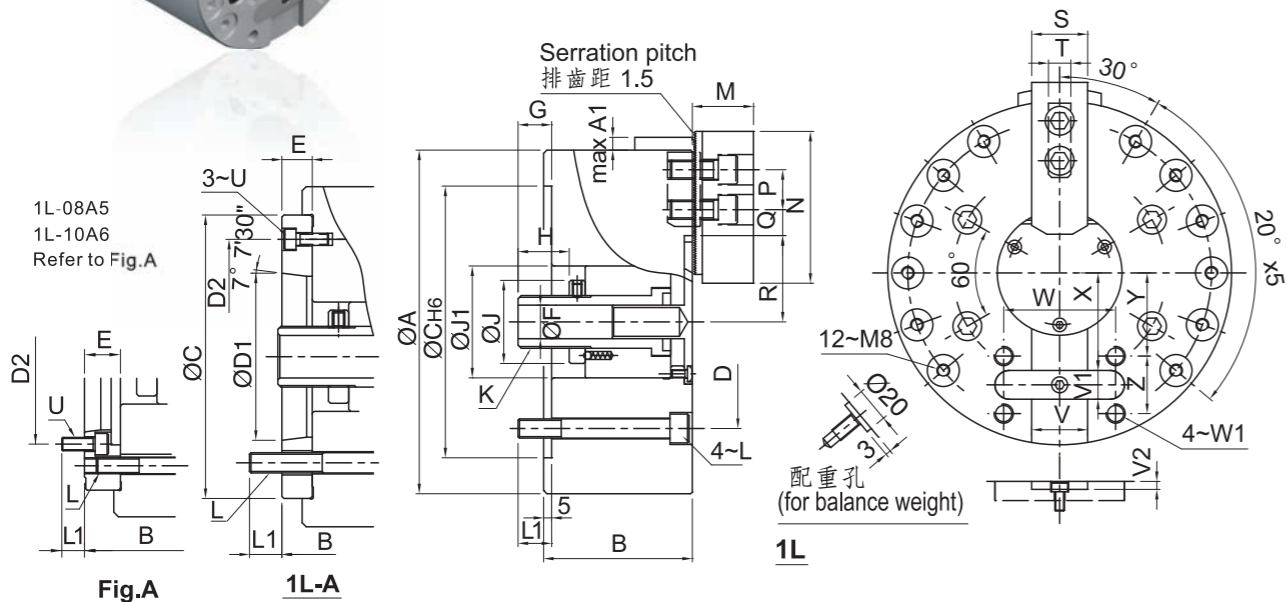

規格 Spec	模心行程 Plunger stroke (mm)	爪行程(直徑) Jaw stroke (Dia.) (mm)	夾持直徑 chucking Dia.(mm)	容許油壓缸推力 Max.D.B.pull KN(kgf)	最大夾持力 Max clamping force kgf	最高回轉速 max r.p.m	慣性矩 kg·m <sup>2</sup>	重量 (kg)	適用回轉缸 Matching cyl.	最大使用壓力 Max.pressure Mpa (kgf/cm <sup>2</sup> )
1L-06	A5	20	168	17	12.3(1250)	27.3(2780)	3800	0.05	12.8 14.6	S-100R 1.7(17.5)
1L-08	A5	25	215	20	15.7(1600)	37.2(3800)	3000	0.15	24.5 25.6	1.4(14.3)
1L-10	A6	30	254	25	21.6(2200)	48.5(4950)	2400	0.28	34.0 41 39.5	S-125R 1.9(19.5)

寸法 Size 型號 Model	A	A1	B	C	D	D1	D2	E	F	G max	G min	H	J	J1	K max	L	L1		
																		M	N
1L-06	A5	168	9.5	80	90	140	104.8	82.56	116	15	37	17	25	46	54	M30X1.5	M10	16	16
1L-08	A5	215	8	93	105	170	133.4	106.38	150	17	46	21	32	52	70	M33X1.5	M12	21	19
1L-10	A6	254	13.5	108	128	220	171.4	139.72	190	18	30	17	30	62	90	M45X1.5	M16	25	20

寸法 Size 型號 Model	M	N	P	Q max	Q min	R max	R min	S	T	U	V(H6)	V1(h9)	V2	W	W1	X	Y	Z
1L-06	A5	37	73	20	19.75	7.75	46	30	31	12	30	15	64	M10	45	36	30	
1L-08	A5	38	95	25	25.25	10.25	54	34	35	14	35	18	4.5	70	61	52	36	
1L-10	A6	43	110	30	33.75	11.25	67	43	40	16	M8	40	20	5	90	71	58.5	45

\* 保留技術更改的權利，恕不另行通知 Subject to technology changes without prior information  
 \* 非標需求可訂做 Non-standard requirements can be made

## ➤ 3J SERIES

### 三爪中實型指形動力夾頭

### FINGER POWER CHUCK



- ◎ 採工件端面夾持，防止工件夾持變形，適合薄壁工件加工。
- ◎ 夾持補償機構，可夾持不規則斷面之工件。
- ◎ 夾頭中心可裝設工件密著確認裝置。
- ◎ Prevent deformation of workpiece for gripping the terminal surface, suitable for thin workpiece process.
- ◎ The compensating mechanism of gripping that can grasp the workpieces of the irregular surface.
- ◎ Additional check device able to install in the center of chuck.

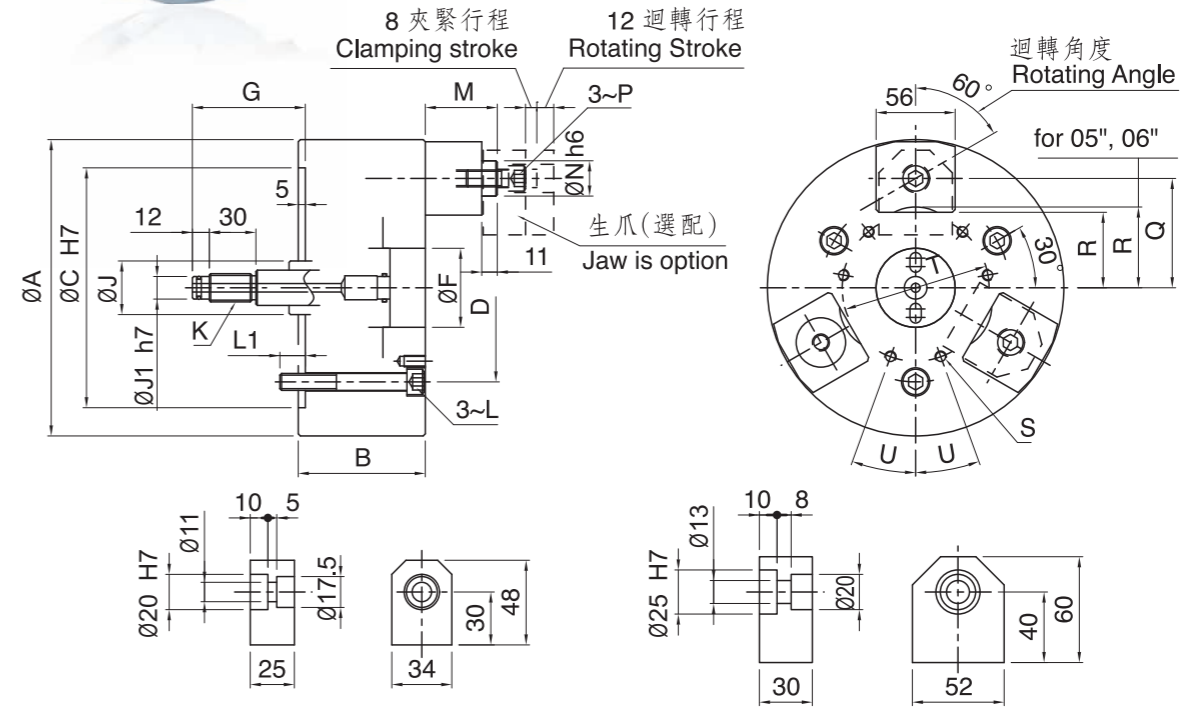

規格 Spec 型號 Model	模心行程 Plunger stroke (mm)	爪行程 Jaw stroke (mm)	夾持直徑 chucking Dia.(mm)		容許油壓缸推力 Max.D.B.pull (kgf)	最大夾持力 Max.clamping force KN(kgf)	最高回轉速 max r.p.m	慣性矩 kg·m <sup>2</sup>	重量 (kg)	適用回轉缸 Matching cyl.	最大使用壓力 Max.pressure Mpa (kgf/cm <sup>2</sup> )
			最大Max	最小Min							
3J-05			53	25	7.5(765)	6.0(612)		0.02	11.0		1.0(10)
3J-06			79	55	9.0(918)	7.5(765)	4000	0.04	12.0	S-100R	1.2(12)
3J-08	12	8	106	75				0.13	23.0	or	
3J-10			150	119	18.0(1835)	16.5(1680)	3500	0.30	33.0	SNK-100	2.5(25)
3J-12			200	169			3000	0.56	44.0		

寸法 Size 型號 Model	A	B	C	D	F	G		J	J1	K	L	L1	M		N	P	Q	R	S	T	U
						max	min						max	min							
3J-05	135	86	110	82.6	40	75	55	25	10	M12X1.75	M10	15	56	36	20	M10	42.5	27	3-M6	50	-
3J-06	165		140	104.8	45			28	14	M16X2							57.5	40	3-M8	64	
3J-08	210	90	170	133.4		80	60				M12	18					77.5	53.5		104	
3J-10	254	95	220	171.4	56	75	55	38	16	M20X2.5	M16	24	71	51	25	M12	99.5	75.5	6-M8	140	20°
3J-12	304																124.5	100.5		190	

\* 保留技術更改的權利，恕不另行通知 Subject to technology changes without prior information  
 \* 非標需求可訂做 Non-standard requirements can be made

## > 2J SERIES

### 二爪中實型指形動力夾頭

### FINGER POWER CHUCK

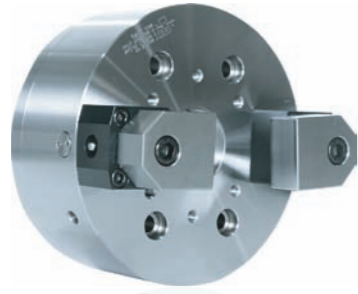

- 採工件端面夾持，防止工件夾持變形，適合薄壁工件加工。
- 夾持補償機構，可夾持不規則斷面之工件。
- 夾頭中心可裝設工件密著確認裝置。
- Prevent deformation of workpiece for gripping the terminal surface, suitable for thin workpiece process.
- The compensating mechanism of gripping that can grasp the workpieces of the irregular surface.
- Additional check device able to install in the center of chuck.

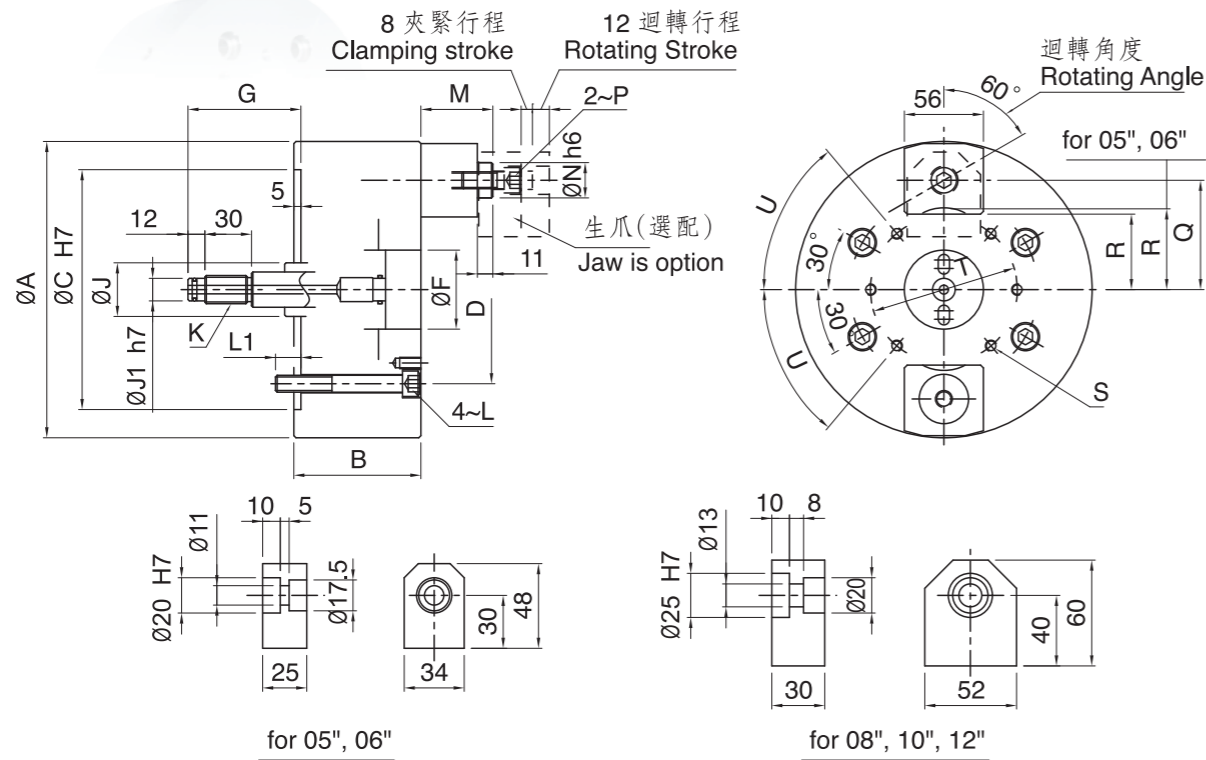

規格 Spec 型號 Model	楔心行程 Plunger stroke (mm)	爪行程 Jaw stroke (mm)	夾持直徑 chucking Dia.(mm)		容許油壓缸推力 Max.D.B.pull KN(kgf)	最大夾持力 Max clamping force (kgf)	最高回轉速 max r.p.m	慣性矩 kg·m <sup>2</sup>	重量 (kg) Weight	通用回轉缸 Matching cyl	最大使用壓力 Max.pressure Mpa (kgf/cm <sup>2</sup> )
			最大Max	最小Min							
2J-05	12	8	53	25	5.0(510)	4.0(408)	4000	0.015	9.0	S-100R	0.7(7)
2J-06			79	55	6.0(612)	5.0(510)		0.035	9.8		0.8(8)
2J-08			106	75	12.0(1224)	11.0(1122)	3500	0.12	20.3	or SNK-100	1.7(17)
2J-10			150	119				0.28	30.7		
2J-12			200	169				0.52	41.2		

寸法 Size 型號 Model	A	B	C	D	F	G		J	J1	K	L	L1	M		N	P	Q	R	S	T	U
						max	min						max	min							
2J-05	135	86	110	82.6	40	75	55	25	10	M12X1.75	M10	15	56	36	20	M10	42.5	27	4-M6	50	30°
2J-06	165	140	140	104.8	45	80	60	28	14	M16X2	M12	18	77.5	53.5			57.5	40	4-M8	64	
2J-08	210	90	170	133.4									99.5	75.5			99.5	75.5	6-M8	140	
2J-10	254				56			38	16	M20X2.5	M16	24	71	51	25	M12	124.5	100.5		190	50°
2J-12	304																				

\* 保留技術更改的權利，恕不另行通知 Subject to technology changes without prior information  
\* 非標需求可訂做 Non-standard requirements can be made

## > VH SERIES

### 中空立式夾頭

### STATIONARY CHUCK WITH THROUGH-HOLE

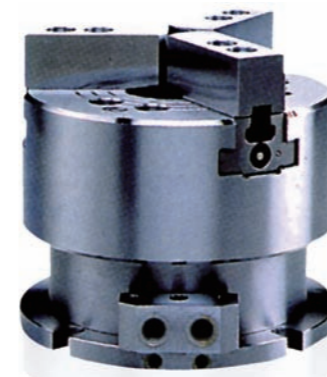

- 立置式中空動力夾頭，適合鑽床，銑床或切削中心機使用，有二爪及三爪兩種形式。
- VH-200型所配對之夾頭規格及寸法與BT型式相同。
- VH-300型所配對之夾頭規格及寸法與B型式相同。
- It's a STATIONARY CHUCKS with two or three jaws for drilling, milling and other machines.
- Specification and size of matching chuck for model VH-200 is the same as model BT.
- Specification and size of matching chuck for model VH-300 is the same as model B.

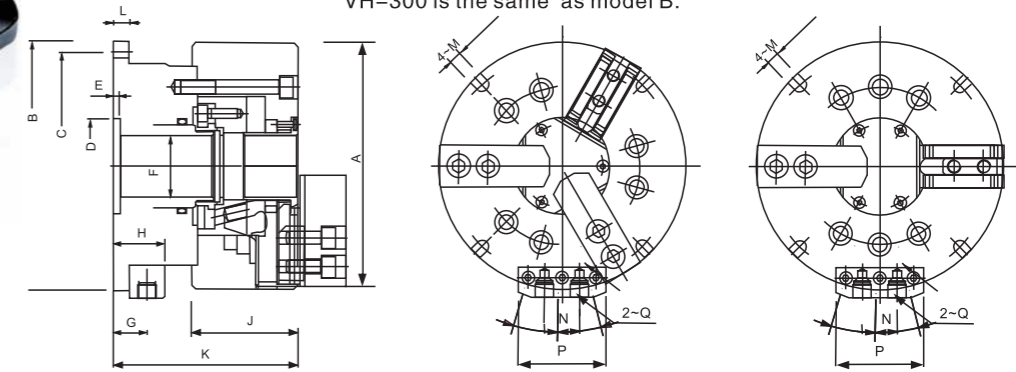

規格 Spec 型號 Model	活塞面積 Eff.piston area cm <sup>2</sup>		爪行程 (直徑) (mm) Jaw stroke	最高使用壓力 Mpa(kgf/cm <sup>2</sup> )	重量(kg) Weight
	伸側 Extend	拉側 Retract			
VH-204 304	49.7	46.5	5.4	2.0(20) 3.0(30)	7.9 8.1
VH-205 305	66.0	57.9	5.4	2.2(22) 3.2(32)	11.7 11.9
VH-206 306	98.9	88.5	5.5	1.8(18) 2.7(27)	19.8 20.2
VH-208 308	125.7	113.9	7.4	2.2(22) 3.2(32)	32.3 33.6
VH-210 310	196.2	182.0	8.8	1.7(17) 2.5(25)	55.5 56.5
VH-212 312	243	217	10.6	1.8(18) 2.6(26)	106.5 106.5
VH-215 315	377	345	10.6	1.7(17) 2.4(24)	163 158

寸法 / Size 型號 / Model	A	B	C	D H8	E	F	G	H	J	K	L	M	P	N	Q	
VH-204 304	110	150	132	50		23	23	34	59	106.5				62	26	PT1/4
VH-205 305	135	168	150	60	5	33	23	34	60	111	12	9		62	26	PT1/4
VH-206 306	169	194	176			45	25	36	81	138				62	26	PT1/4
VH-208 308	210	212	190	80		52	29	44	91	158	14	14		75	30	PT3/8
VH-210 310	254	266	246	90	6	70	32	47	100	190	17	17		75	30	PT3/8
VH-212 312	304	375	340	110	10	90	37	55	110	205	23	18		75	30	PT3/8
VH-215 315	381	400	376	130	12.5	117	40	58	133	227	25	22		75	30	PT3/8

\* 保留技術更改的權利，恕不另行通知 Subject to technology changes without prior information  
\* 非標需求可訂做 Non-standard requirements can be made

## > VP SERIES

### 中實立式夾頭

### NON-THRU-HOLE STATIONARY 2/3-JAW POWER CHUCK

- ◎ 立置式中實動力夾頭，適合鑽床、銑床或切削中心機使用，有二爪及三爪兩種形式。
- ◎ VP-200型式所配對之夾頭規格及寸法與TL型式相同。
- ◎ VP-300型式所配對之夾頭規格及寸法與T型式相同。
- ◎ It's STATIONARY CHUCKS with two or three jaws for drilling, milling and other machines.
- ◎ Specification and size of matching chuck for model VP-200 is the same as model TL.
- ◎ Specification and size of matching chuck for model VP-300 is the same as model T.

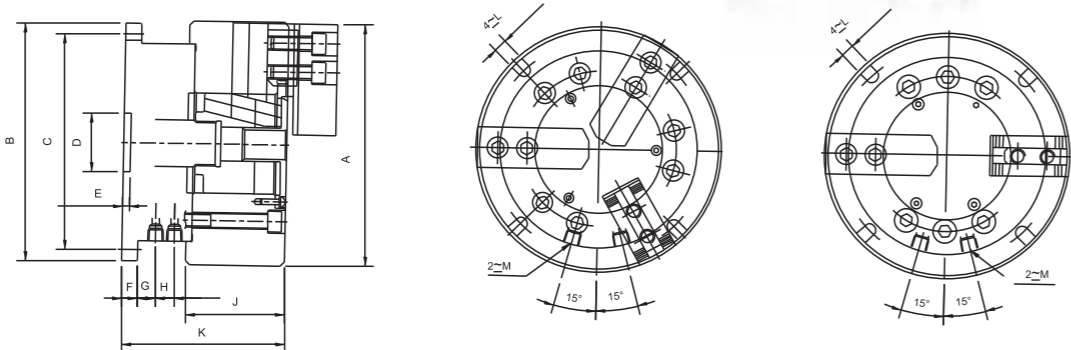

規格 Spec 型號 Model	活塞面積 Eff.piston area cm <sup>2</sup>		爪行程 (直徑) (mm) Jaw stroke	最高使用壓力 Mpa(kgf/cm <sup>2</sup> )	重量(kg) Weight
	伸側 Extend	拉側 Retract			
VP-204 304	28.0	24.9	6.4	2.1(21)	7.1
VP-205 305				3.1(31.5)	7.9
VP-206 306	63.1	53.5	8.5	2.3(23.3)	10.2
VP-208 308				3.5(35)	10.6
VP-210 310	153.1	133.5	8.8	2.4(24)	18.3
VP-212 312				3.6(36)	19.3
VP-215 315	292	275	16	2.0 (20)	31.6
VP-308				3.0(30)	33.6
VP-310	1.6(16)	52.8			
VP-312	2.3(23)	54.5			
VP-315	2.0(20)	117			
VP-315	2.8(28)	119			
VP-315	2.6(26)	160			
VP-315	3.1(31)	165			

規格 Spec 型號 Model	A	B	C	D H7	E	F	G	H	J	K	L	M
VP-204 304	110	146	130	30	4.5	12	23	26	52	92	9	PT1/4
VP-205 305	135											
VP-206 306	165	178	160	40	5	14	29	85	140	11	PT3/8	
VP-208 308	210	205	186									
VP-210 310	254	248	225	50	17	32	30	89	176	13		
VP-212 312	304	375	340	110	23	37		106	206	18		
VP-215 315	381	400	376	130	10	25	40	114	228	22		

\* 保留技術更改的權利，恕不另行通知 Subject to technology changes without prior information  
\* 非標需求可訂做 Non-standard requirements can be made

## > LL SERIES

### 筒夾夾頭一

### COLLET CHUCK 1



- ◎ 前推式彈性筒夾夾頭，適合CNC車床，專用機，或其他旋削機械。
- ◎ 高精度，高轉數及高剛性結構。
- ◎ 安裝連結方式與中空夾頭一樣，且可與之相容互換，不必更改拉桿
- ◎ 全面防水設計，防止切削水進入主軸通孔處
- ◎ It's a PUSH type collet are used mainly on turning, CNC , special purpose machines and other , etc.
- ◎ High clamping accuracy, high speed and construction of high rigidity.
- ◎ The installation is the same as "Thru-hole power chuck" and they are replaceable with each other. No need to change the "Draw tube".
- ◎ Sealed against swarf, chips and coolant.
- ◎ 搭配彈性筒夾須符合DIN 6343 規範。
- ◎ The collet used must accord with DIN 6343



視全套定位銷孔為選配加工。  
定位銷為選購件。  
※注：當彈性筒夾為夾持方形或六角材時請于訂購時選配追加定位銷孔與定位銷。  
The hole and lock pin is option.  
Note:While clamp square or hexagonal material, please order hole and lock pin of collet chuck

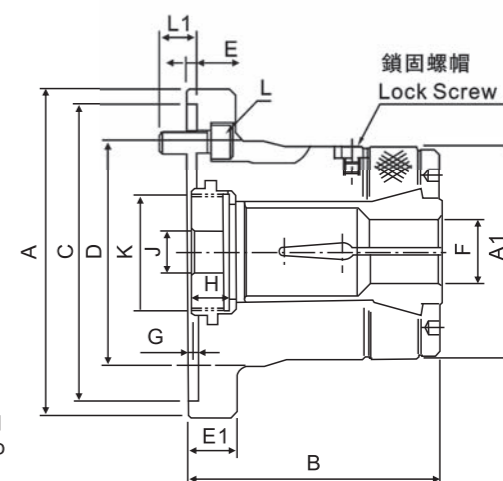

寸法 Size 型號 Model	套筒行程 Plunger stroke mm	最大夾持能力 Max.Chucking Capacity (mm)			容許油壓缸推力 Max.D.B.pull kN(kgf)	最大夾持力 Max.clamping force kN(kgf)	最高回轉速 max.r.p.m	慣性矩 kg-m2	重量 Weight (Kg)	使用筒夾 Matching Stell Collet	適用油壓缸 Matching cyl	最大使用壓力 Max.pressure Mpa (kgf/cm <sup>2</sup> )
		圓棒Round	六角料 Hexagonal	方料Square								
LL-26	4.5	3~26	4~22	4~18	17.6(1800)	37.9(3870)	8000	0.040	4.3	161E	H-0928	2.6(26)
LL-30		3~30	4~26	4~20	19.6(2000)	42.1(4300)		0.038	4.2	163E	H-1036	2.9(29)
LL-36	6	3~36	6~32	6~26	22.5(2300)	48.5(4950)	6000	0.062	7.0	171E	H-1246	2.5(25)
LL-42		3~42	6~36	6~29	24.5(2500)	52.9(5400)		0.060	6.9	173E	H-1246	2.9(29)
LL-52		5~52	8~45	7~36	27.4(2800)	59.0(6020)		0.101	14.3	177E	H-1552	2.3(23)
LL-6017		5~60	8~52	7~42	29.4(3000)	63.7(6500)		0.098	14.1	185E	H-1875	1.8(18)
LL-6022								0.126	16.3			
LL-80		20~80	18~69	15~56	34.3(3500)	71.5(7300)		0.108	17.8	193E	H-2091	1.6(16)

寸法 Size 型號 Model	A	A1	B	C(H6)	D	E	E1	Fmax	Fmin	Gmax	Gmin	H	J	Kmax	L	L1
LL-26	120	85	100	110	82.6	4	26	30	7	2.5	15	12	M40X1.5	3~M10X25	16	
LL-30																
LL-36	155	100	120	140	104.8	5	23	36	3	7	1	17.5	20	M55X2	20	
LL-42																
LL-52																
LL-6017	185	130	145.5	170	133.4	5	27	52	5	9	3	24	45	M60X2 M75X2	6~M12X30	20
LL-6022	234	156	142	220	171.5	32	80	20	13	7	9.5	24	45	M85X2 M100X2	6~M16X30	20
LL-80																

\* 保留技術更改的權利，恕不另行通知 Subject to technology changes without prior information  
\* 非標需求可訂做 Non-standard requirements can be made

## > LL-A SERIES

### 筒夾夾頭二

### COLLET CHUCK 2

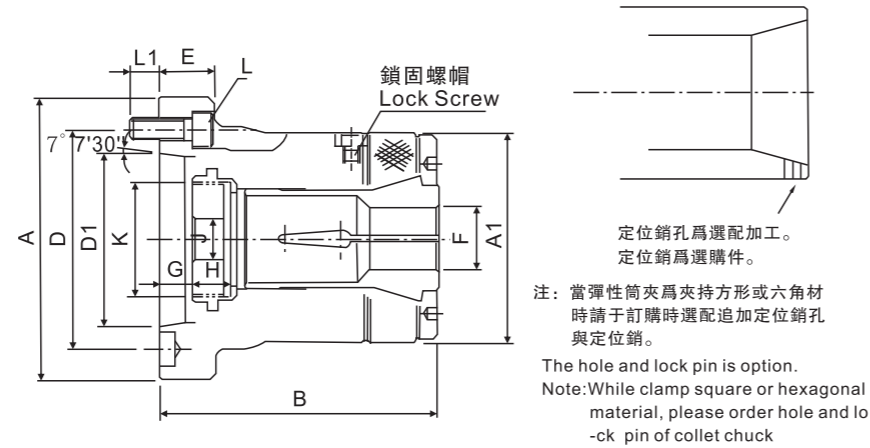

寸法 型號 Model	套筒行程 Plunger stroke (mm)	最大夾持能力 Max. Chucking Capacity (mm)			容許油壓缸推力 Max. D.B. pull kN(kgf)	最大夾持力 Max. clamping force kN(kgf)	最高回轉速 max r.p.m	慣性矩 kg·m <sup>2</sup>	重量 Weight (Kg)	使用筒夾 Matching Stell Collet	適用油壓缸 Matching cyl	最大使用壓力 Max. pressure Mpa (kgf/cm <sup>2</sup> )
		圓棒 Round	六角料 Hexagonal	方料 Square								
LL-26 A4	4.5	3~26	4~22	4~18	17.6(1800)	37.9(3870)	8000	0.040	4.2	161E	H-0928	2.6(26)
LL-30 A4		3~30	4~26	4~20	19.6(2000)	42.1(4300)		0.038	4.1	163E	H-1036	2.9(29)
LL-36 A5	6	3~36	6~32	6~26	22.5(2300)	48.5(4950)	6000	0.058	6.3	171E	H-1246	2.5(25)
LL-42 A5		3~42	6~36	6~29	24.5(2500)	52.9(5400)		0.057	6.1	173E	H-1246	2.9(29)
LL-52 A6	6	5~52	8~45	7~36	27.4(2800)	59.0(6020)	5000	0.093	13.8	177E	H-1552	2.3(23)
LL-60 A6		5~60	8~52	7~42	29.4(3000)	63.7(6500)		0.091	13.5	185E	H-1875	1.8(18)
LL-80 A8	6	20~80	18~69	15~56	34.3(3500)	71.5(7300)	4000	0.104	14.5	193E	H-2091	1.6(16)

寸法 型號 Model	A	A1	B	D	D1	E	F max	F min	G max	G min	H	J	K max	L	L1
LL-26 A4	110	85	108	82.6	63.51	25	26	3	9.5	5	15	12	M40X1.5	3~M10X30	15
LL-30 A4							30								
LL-36 A5	135	100	130	104.8	82.56	27	36	14	8	17.5	20	M55X2	4~M10X30	14	
LL-42 A5							42								
LL-42 A6	165	100	130	104.8	82.56	27	42	16	11	17.5	20	M60X2	4~M12X30	16	
LL-52 A6							52								
LL-52 A6	170	130	154	133.4	106.38	27	52	10.5	4.5	24	45	M75X2	4~M12X35	20	
LL-60 A6							60								
LL-60 A8	210	156	175	171.5	139.72	35	60	3.5	-2.5	24	45	M85X2	4~M16X40	22	
LL-80 A8							80								
LL-80 A8	210	156	175	171.5	139.72	35	80	7.5	1.5	24	45	M100X2	6~M16X40	22	
LL-80 A8							80								

### 彈性筒夾

### Collet

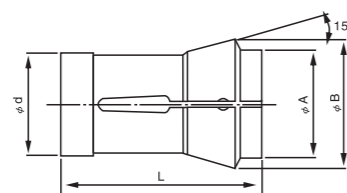
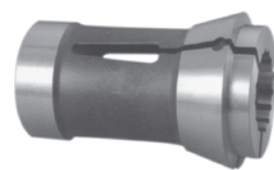

### 規格 / Specification

規格 Model	A	B	d	L	Max Dia		
					○	◻	◻
161E	39	45	32	75	26	22	18
163E	39	49	35	80	30	27	22
171E	42	55	42	94	37	32	26
173E	50	60	48	94	42	36	28
177E	60	70	58	94	52	45	36
185E	73	84	66	110	60	50	40
193E	92	107	90	130	80		

\* 保留技術更改的權利，恕不另行通知 Subject to technology changes without prior information  
\* 非標需求可訂做 Non-standard requirements can be made

## > LLT SERIES

### LLT 後拉式筒夾夾頭

### LLT PULL BACK COLLET CHUCK



- ◎ 后拉式筒夾夾頭，適用於各種旋削機械及數控車床。
- ◎ 安裝方便，與中空夾頭相同，可相容互換。
- ◎ 可使棒料從夾頭的通孔進行送料作業。
- ◎ 不同尺寸及形狀的工件，可選用合適的彈簧夾頭。

- ◎ Pull back collet chuck
- ◎ It's applicable for various CNC machines.
- ◎ Easy installation, the installation size is compatible with the related hydraulic chucks.
- ◎ The bar workpiece can be input through the collet chuck hole.
- ◎ The collet is optional for different size and shape workpiece.

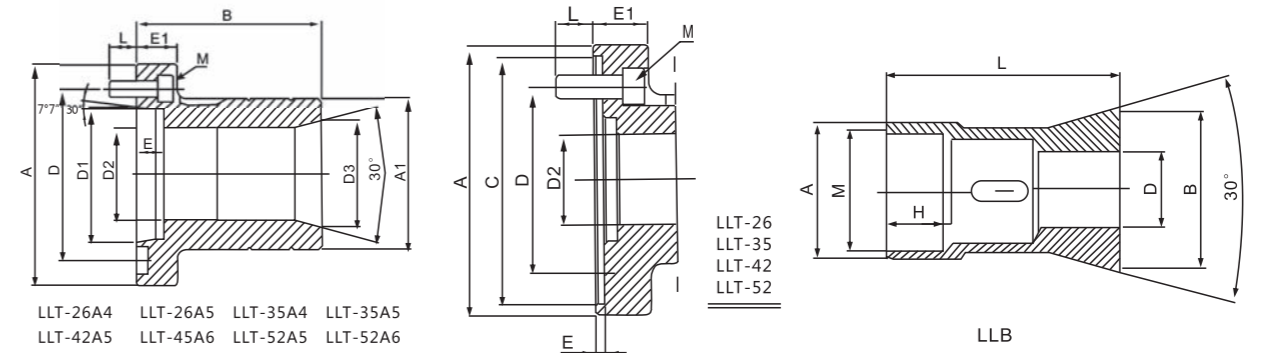

型號 Model	A	A1	B	C(H6)	D	D1	D2	D3	E	E1	L	M
LLT-26	120	120	110	110	82.6		40	48	4	25	17	3~M10*25
LLT-35	120	83	110	110	82.6		49	58	4	25	17	3~M10*25
LLT-42	155	90	115	140	104.8		56	65	5	25	17	4~M10*25
LLT-52	155	106	125	140	104.8		65	73	5	25	17	4~M10*25
LLT-26A4	112	73	110		82.6	63.51	40	48	17	25	17	3~M10*30
LLT-26A5	135	73	110		82.6	82.56	40	48	17	25	17	3~M10*30
LLT-35A4	112	83	110		82.6	63.51	49	58	17	25	17	3~M10*30
LLT-35A5	135	83	110		82.6	82.56	49	58	17	25	17	3~M10*30
LLT-42A5	135	90	115		104.8	82.56	56	65	17	25	17	4~M10*30
LLT-42A6	165	90	115		133.4	106.38	56	65	17	30	17	4~M12*30
LLT-52A5	135	106	125		104.8	82.56	65	73	17	25	17	4~M10*30
LLT-52A6	165	106	125		133.4	106.38	65	73	17	30	17	4~M12*30

型號 Model	A (g6)	B	D max 圓棒 Round	D max 六角料 Hexagonal	D max 方料 Square	H	L	M
LLB-26	40	49	26	22	18	27	95	M33*1.5
LLB-35	49	59	35	32	26	27	95	M42*1.5
LLB-42	56	66	42	42	29	27	100	M50*2
LLB-52	65	74	52	52	36	27	100	M55*2

\* 保留技術更改的權利，恕不另行通知 Subject to technology changes without prior information  
\* 非標需求可訂做 Non-standard requirements can be made

### > FR SERIES

#### FR擺動補償型三爪夾頭

#### SWING COMPENSATION TYPE 3 JAW CHUCK

- ◎ 工件偏心補償量2mm，中心頂針定位，三爪擺動夾持工件。
  - ◎ 適合鑄件及鍛件等原材料進行加工。
  - ◎ 特殊密封圈，防塵及防切削液，使保養工作更加便利。
  - ◎ 擺動機構零件均以合金鋼加以熱處理硬化及研磨，以提升產品使用壽命。
- ◎ The compensation for eccentric workpiece is 2mm, positioned by the core center, 3 jaw clamp the workpiece by swing way.
  - ◎ Suitable for processing casting and forging parts.
  - ◎ Special seal ring, dustproof and waterproof, easy maintenance
  - ◎ Swing parts are hardened by heat treatment and ground.

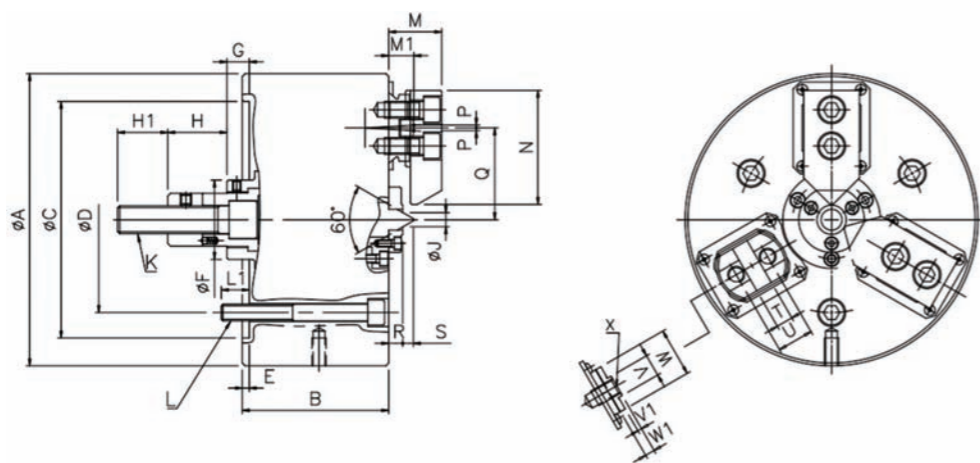

型式 Model	楔心行程 Plunger stroke (mm)	爪行程(直徑) Jaw stroke (Dia) (mm)	最大夾持直徑 Max. clamping dia (mm)	最小夾持直徑 Min. clamping dia (mm)	最大容許油壓缸推力 Max. D.B. pull kN (kgf)	最大夾持力 Max. clamping force kN (kgf)	最高回轉數 Max RPM	重量 Weight (kg)	適用油缸 Matching Cylinder	補償量 Compensation (mm)	
FR-08	20	8	65	18	19.6(2000)	53.0(5404)	2800	0.15	27	SNK-100	2
FR-10	25	10	90	22	29.4(3000)	67.7(6901)	2500	0.38	45	SNK-125	2

型式 Model	A	B	C(H6)	D	E	F	G max	G min	H	H1	J	K	L	L1
FR-08	210	105	170	133.4	5	57	26	6	42.5	36	10.4	M20x2.5	3-M12	20
FR-10	254	115	220	171.4	5.5	64	36.5	11.5	25	39	15	M20x2.5	3-M16	22.5

型式 Model	M	M1	N	P	Q max	Q min	R	S	T(H7)	U	V	V1	W	W1	X
FR-08	38	18	82	2	68	64	10	7.7	12	26	16	3	35	7	M12
FR-10	40	19	102	2.6	82	78	10	11.3	15	32	18	3	40	7	M14

\* 保留技術更改的權利，恕不另行通知 Subject to technology changes without prior information  
 \* 非標需求可訂做 Non-standard requirements can be made

### > FW SERIES

#### FW三爪強力浮動油壓卡盤

#### 3 JAW SWING LOCK CHUCK

- ◎ 適用於鑄造和鍛造工件的自定心車削加工
- ◎ 工件夾緊後拉，能夾持10度的錐體，卡爪可左右搖擺5度。
- ◎ 重複定位精度可達0.03mm
- ◎ Suitable for self centering turning process for casting and forging workpiece
- ◎ Clamping and drawing back the workpiece, it can clamp the parts with 10 degree taper, and the chuck jaws can swing 5 degree.
- ◎ The accuracy for repeatability position can meet 0.03mm

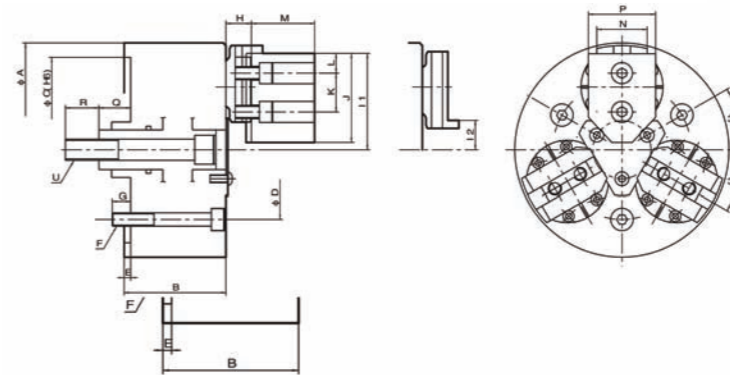

型號 Model 規格 Spec	夾持外徑 Clamping out dia (mm)	夾持內徑 Clamping inner dia (mm)	柱塞行程 Plunger Stroke (mm)	爪行程(直徑) Jaw stroke (Dia.) (mm)	最高回轉數 Max RPM	最大容許油壓缸推力 Max. D.B. pull kN	最大靜夾持力 Max. clamping force kN	適用油缸 Matching Cylinder	重量 Weight (kg)
FW-06	12.7-120	70-152	11.4	7.9	4000	23	70	S-125R	14.8
FW-08	16-152	76-203	14.2	9.5	3500	32	96	S-125R	23.7
FW-10	50-203	85-235	17.5	12.7	3200	40	123	S-150R	39.5
FW-12	63-241	127-305	17.5	12.7	2500	40	123	S-150R	58.5
FW-15	78-310	170-380	22.4	15.8	1800	54	165	S-200R	95.2
FW-18	90-390	245-455	22.4	15.8	1500	55	166	S-200R	145
FW-21	165-470	320-530	22.4	15.8	1000	56	167	S-200R	180

型號 Model 規格 Spec	A	B	C	D	E	F	H	I1	I2
FW-06	162	77	140	104.8	5	3-M10	14.3	73	22.2
FW-08	200	88	170	133.4	5	3-M12	19.3	89	25
FW-10	254	105	220	171.4	5	3-M16	24.5	112.8	30.2
FW-12	300	105	220	171.4	5	3-M16	24.5	133.3	50.7
FW-15	381	120	300	235	6	3-M20	29	171.15	69.85
FW-18	457	126.5	380	260	6	3-M24	29	209.65	108.35
FW-21	533	126.5	380	330.2	6	3-M24	29	248	146.7

型號 Model 規格 Spec	J	K	L	M	N	P	Q	R	U
FW-06	68	29.4	15	44	38.1	50	17.6-29	30	M16
FW-08	81	34	15	54	44.45	55	20-34	30	M18
FW-10	100	44.5	19	64	57	70	23.5-41	35	M22
FW-12	110	44.5	19	64	57	70	20-37.5	38	M22
FW-15	140	54	24	74	66.7	80	29.6-52	40	M24
FW-18	140	54	24	74	66.7	80	16.4-38.7	41	M30
FW-21	170	54	24	74	66.7	80	16.4-38.7	41	M30

\* 保留技術更改的權利，恕不另行通知 Subject to technology changes without prior information  
 \* 非標需求可訂做 Non-standard requirements can be made

## > FQ SERIES

### FQ 快拆式動力夾頭

#### QUICK JAW CHANGE CHUCK

- ◎ 最短的生爪更換時間，重複精度高。
- ◎ 夾頭本體及內部零件均硬化及精密研磨，並直接潤滑。
- ◎ 高剛性結構及高夾持精度。
- ◎ 如主爪與排齒沒有完全齒合，主爪安全裝置不復位。
- ◎ shortest time for changing soft jaw, and high repeatability precision.
- ◎ The chuck body and all parts are hardened and ground, it can be lubricated directly.
- ◎ high rigidity construction and high clamping accuracy.
- ◎ For safety system that master jaw will complete return when base jaw and serration match up properly.

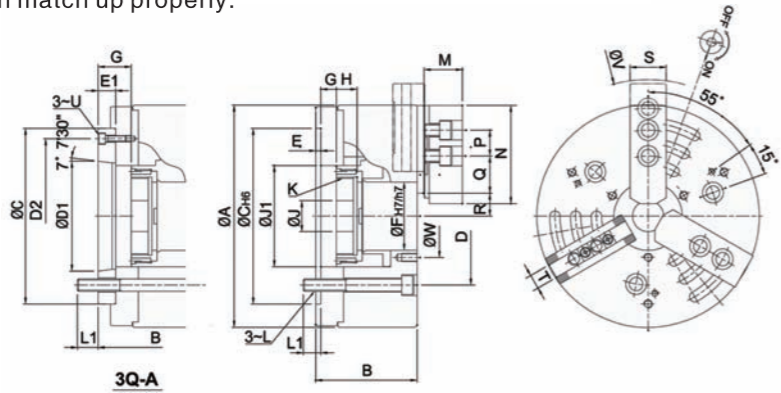

型式 Model	連接盤 Adapter	楔心行程 Plunger stroke (mm)	爪行程(直徑) Jaw stroke (Dia) (mm)	最大夾持直徑 Max. clamping dia (mm)	最小夾持直徑 Min. clamping dia (mm)	最大容許油壓缸推力 Max. D.B. pull kN (kgf)	最大夾持力 Max. clamping force kN (kgf)	最高回轉數 Max RPM	kg·m <sup>2</sup>	重量 Weight (kg)	重量 (含連接盤) Weight (kg)	適用油缸 Matching Cylinder	最大使用壓力 Mpa (kgf/cm <sup>2</sup> )
FQ-08	A6	16	7.5	210	23	45.0(4590)	100.0(10200)	5000	0.15	24.5	26	H-1778	3.1(31)
FQ-10	A8	19	8.8	254	41	60.0(6118)	135.0(13765)	4500	0.41	44	46	H-2085	2.8(28)
FQ-12	A8	23	10.6	315	47	81.0(8259)	180.0(18354)	3500	0.96	73	75	H-2511	2.4(25)

型式 Model	連接盤 Adapter	A	B	B	C	D	D1	D2	E	E1	F	G max	G max	G min	G min	H	J
FQ-08	A6	215	98	110	170	133.4	106.38	150	5	17	66	14.5	32	-1.5	15.5	20	30
FQ-10	A8	254	119	132	220	171.4	139.72	190	5	18	81	8.5	26.5	-10.5	7.5	39	45
FQ-12	A8	315	133	145	220	171.4	139.72	190	6	18	106	8.5	26.5	-14.5	3.5	42	50

型式 Model	連接盤 Adapter	J1	K max	L	L1	L1	M	N	P	Q	R max	R min	S	T	U	V	W
FQ-08	A6	98	M75x2	M12	17	20	37	95	25	36	20.8~44.8	17.1~41.1	35	14	M6	264	80
FQ-10	A8	115	M90x2	M16	23	25	42	110	30	40.5	21.1~52.8	16.7~48.2	40	16	M8	312	100
FQ-12	A8	140	M115x2	M16	22	24	50	111	30	57	34.1~70.1	28.8~64.8	50	21	M8	360	130

\* 保留技術更改的權利，恕不另行通知 Subject to technology changes without prior information  
\* 非標需求可訂做 Non-standard requirements can be made

## > 4TT SERIES

### 四爪雙動夾頭

#### 4-JAW TWO-TWO MOTION POWER CHUCK

- ◎ 曲柄型兩兩動作夾頭
- ◎ 適用於方形或异形工件
- It's a crank type chuck with independent motion of each two jaws. it's applicable for clamping square bar or other special shape workpiece.

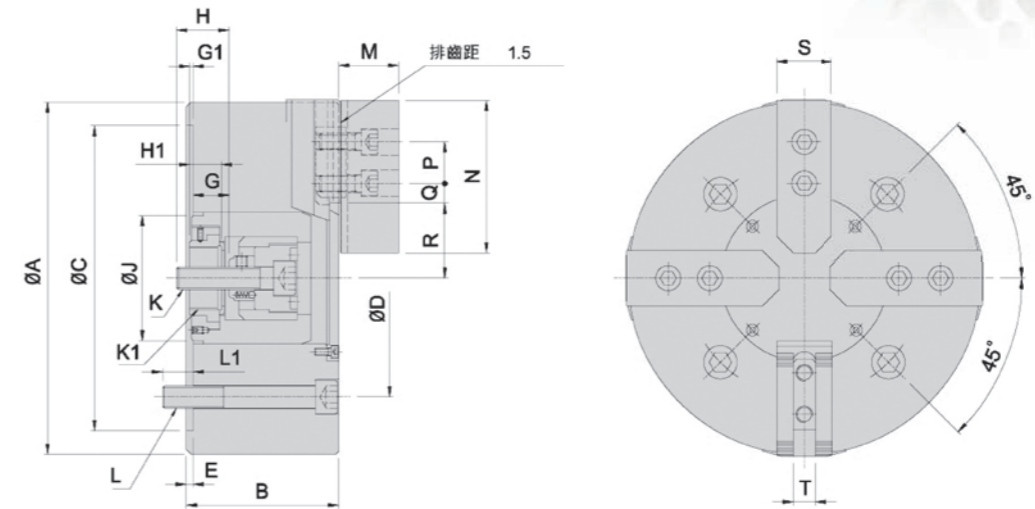
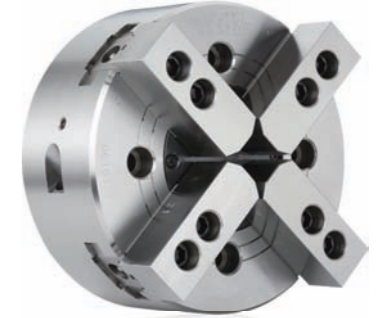

型號/Model	楔心行程 Plunger stroke (mm)	爪行程(直徑) Jaw stroke (dia.) (mm)	最大夾持直徑 Max. clamping dia. (mm)	最小夾持直徑 Min. clamping dia. (mm)	最大容許油壓缸推力 Max. D.B. pull KN	最大夾持力 Max. clamping force KN	最高回轉數 Max RPM	最高使用壓力 Max Pressure (Mpa)	重量 Weight (kg)	適用油缸 Matching Cylinder
4TT-08	17	13.6	210	24	16.0	54.3	3000	1.7	23.2	SRD-120N
4TT-10	20	16	254	50	21.6	79.4	2100	2.2	44.3	SRD-125N
4TT-12	20	16	304	50	21.6	79.4	1500	2.2	57.6	SRD-125N
4TT-15	25	19.6	381	60	27.2	105.3	1200	2.7	118.3	SRD-125N

型號/Model	A	B	C(H6)	D	E	G Max.	G Min.	G1 Max.	G1 Min.	H	H1	J	K
4TT-08	210	91	170	133.4	5	32	15	2.5	-14.5	29	20	61	M14*2
4TT-10	254	110	220	171.4	5	36.5	16.5	10	-10	36	23	90	M16*2
4TT-12	304	110	220	171.4	5	36.5	16.5	10	-10	36	23	90	M16*2
4TT-15	381	135	300	235	6	44.5	19.5	5	-20	45	28	125	M20*2.5

型號/Model	K1	L	L1	M	N	P	Q Max.	Q Min.	R Max.	R Min.	S	T
4TT-08	M34*1.5	4-M2	20	38	95	25	25.25	13.25	46.1	39.3	35	14
4TT-10	M45*1.5	4-M16	25	43	110	30	32.25	12.75	59	51	40	16
4TT-12	M45*1.5	4-M16	25	43	110	30	54.75	15.75	59	51	40	16
4TT-15	M55*2	4-M20	30	51	130	30	66.5	12.5	78.9	69.1	50	21

\* 保留技術更改的權利，恕不另行通知 Subject to technology changes without prior information  
\* 非標需求可訂做 Non-standard requirements can be made



## > IAH SERIES

### 自動分度卡盤

### AUTO-INDEXING CHUCK



- 一次夾持就可以進行多面加工
- 機械主軸在回轉中也可以自動移換角度
- 內裝止回閥，在發生停電等緊急情況時也可以確保安全性
- 可以分割成4x90°、8x45°，獲得高分割精密度
- Machine multiple surfaces in a single clamping
- On-the-fly indexing
- Accurate, durable indexing system
- Index positions 4x90° or 8x45°

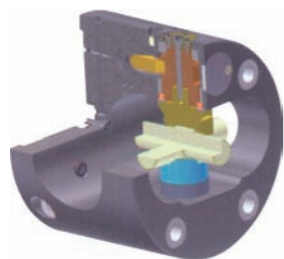

### SPECIAL CHUCK

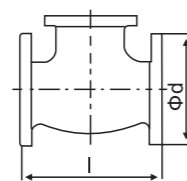

	最大工件尺寸 Max. Workpiece Size	
	Φd[mm]	l[mm]
IAH-225	60	100
IAH-250	65	160
IAH-275	80	220
IAH-315	100	230
IAH-350	135	240
IAH-400	170	260
IAH-500	220	310
IAH-670	300	400

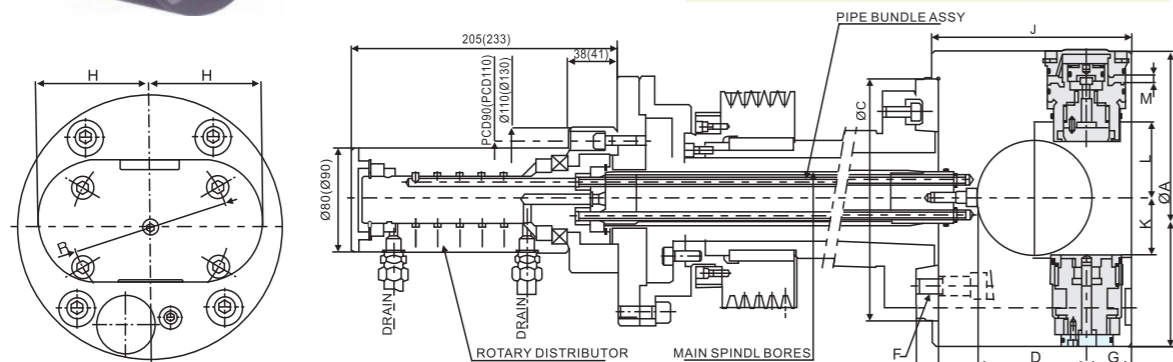

括号内的尺寸是产品型号IAH400和更大的 bracketed dimensions refer to models IAH-400 and larger.

型號 Model	ØA	B	ØC(h7)	D	E	F	G	H	J	K	L	M	ØR
IAH-225	225	149	185	84	25	M12	35	95	154	46	58	11.5	133.4
IAH-250	250	185	210	113	25	M12	40	106	190	46	55	20	133.4
IAH-280	280	208	210	125	25	M16	48	125	213	57	67	20.5	171.4
IAH-315	315	227	235	136	25	M16	50	136	232	70	85	22	171.4
IAH-350	350	235	290	148	30	M20	50	145	240	84	102	23	235
IAH-400	400	253	290	160	30	M20	60	165	259	100	114	30	235
IAH-500	500	301	380	200	35	M20,M24	68	205	308	133	157	35	235
IAH-670	670	465	380	286	40	M24	90	275	470	176	214	40	330.2

Type	夾緊力 (kgf) Max. Clamping Force	主軸孔徑 (mm) Main Spindle Bore	最高回轉速 Max R.P.M	重量 Weight (kg)	慣性矩 kg·m <sup>2</sup>	最大工件尺寸 Ø Max. Workpiece Size	
						S(mm)	T(mm)
IAH-225	1270	OVER45	2800	29	0.9	60	100
IAH-250	1730		2400	44	1.7	65	160
IAH-280	2550		2000	56	2.8	80	220
IAH-315	2550		1800	75	5.0	100	230
IAH-350	2550	OVER55	1800	100	8.0	135	240
IAH-400	3530		1200	145	15.0	170	260
IAH-500	4670		900	230	25.4	220	310
IAH-670	5890		600	540	32.5	300	400

\* 保留技術更改的權利，恕不另行通知 Subject to technology changes without prior information  
\* 非標需求可訂做 Non-standard requirements can be made

## > RT SERIES

### 回轉氣壓夾盤

### RT ROTARY AIR CHUCK FIXTURES



輕切削加工適用 Suitable for light cutting

回轉式氣壓夾盤適用於分度盤，具可隨分度盤主軸旋轉功能，動力夾持加工物作角度分割或旋轉切削。

It's ideal for dividing or cutting work pieces by mounting the chuck on indexing table or rotary table. The distinctive feature is that the chuck rotates with the spindle of indexing table or rotary table.

- 氣缸防銹處理：在潮濕及工作環境較差的情況，氣缸內部經防銹處理，不會生銹或卡死。
- 防塵裝置：工作中的鐵屑及切削液不易進入夾盤內部的缸式，確保夾盤的使用壽命及精度保持。
- 前置式氣缸：氣缸與夾盤直結設計，確保夾持的穩定性，更方便於組裝及操作。

- Rustproof treated cylinder: The cylinder won't get rusty and seized even in wet or high moisture working environment.
- Dust and water proof cover: Prevent metal chips or coolant from entering inside of chuck cylinder to maintain its accuracy and lead to longer service life.
- Integral pneumatic cylinder: Connect chuck and built-in cylinder to each other directly; thus enables operation stability. Moreover, it is more convenient for installation and operation since the use of draw tube and draw bar are no longer necessary.

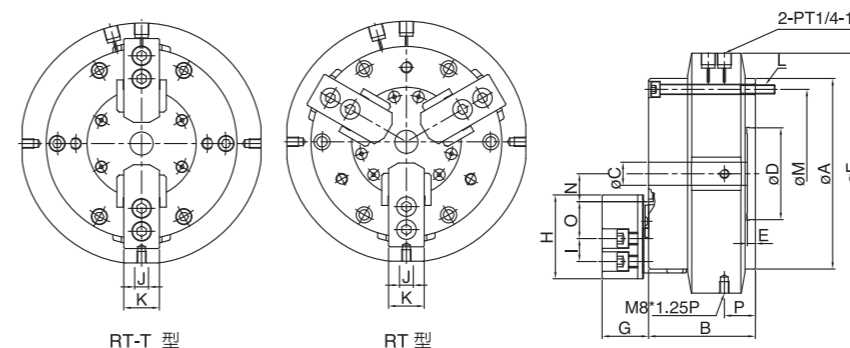

使用範例/Operation Example

規格 Spec 型號 Model	A	B	C	D	E	F	G	H	I	J	K	L
RT-05	140	85	16	60	6	180	33	62	14	10	25	6-M8x1.25P
RT-06	170	93	20	80	7	210	40	73	20	12	31	6-M8x1.25P
RT-08	215	112	30	110	8	250	42	95	25	14	35	6-M10x1.5P
RT-10	255	120	43	140	8	290	46	110	30	16	40	6-M10x1.5P
RT-05T	140	85	16	60	6	180	33	62	14	10	25	6-M8x1.25P
RT-06T	170	93	20	80	7	210	40	73	20	12	31	6-M8x1.25P

規格 Spec 型號 Model	M	P	N <sub>max</sub>	N <sub>min</sub>	O <sub>max</sub>	O <sub>min</sub>	通孔直徑 (mm) Thru-Hole (Diameter)	活塞面積 Piston Area (cm <sup>2</sup> )	柱塞行程 Plunger Stroke (mm)	爪行程 (直徑) Jaw Stroke (Diameter) (mm)
RT-05	PCDØ118	27	26.93	24.62	20.05	6.55	16	74	10	4.6
RT-06	PCDØ147	27	36.46	33.69	21.55	15.55	20	120	13	5.5
RT-08	PCDØ185	28	44.92	41.52	29.55	17.55	30	190	16	6.8
RT-10	PCDØ220	30.5	53.63	49.59	36.55	17.05	43	280	19	8.0
RT-05T	PCDØ118	27	26.93	24.62	20.05	6.55	16	74	10	4.6
RT-06T	PCDØ147	27	36.46	33.69	21.55	15.55	20	120	13	5.5

規格 Spec 型號 Model	最高回轉速 Max R.P.M	最大設定壓力 Max. Pressure (kgf/cm <sup>2</sup> ) (Mpa)	氣壓夾持力 Gripping Force At Air Pressure 7kgf/cm <sup>2</sup> (0.7Mpa) kgf (KN)	夾持範圍 Gripping Range (mm)	淨重 Weight (kg)
RT-05	51	7 (0.7)	1340 (13.1)	Ø4-Ø136	9.3
RT-06	41	7 (0.7)	2330 (22.8)	Ø25-Ø166	15.5
RT-08	33	7 (0.7)	3730 (36.5)	Ø33-Ø215	28.5
RT-10	26	7 (0.7)	5480 (53.7)	Ø43-Ø255	42.3
RT-05T	51	7 (0.7)	1340 (13.1)	Ø4-Ø136	9.0
RT-06T	41	7 (0.7)	2330 (22.8)	Ø25-Ø166	15.0

\* 保留技術更改的權利，恕不另行通知 Subject to technology changes without prior information  
\* 非標需求可訂做 Non-standard requirements can be made

## > RTS SERIES

### 回轉氣壓夾盤

#### MOUNTING ADAPTERS ON SHORT TAPER SPINDLE NOSES DIN 55026

- ◎ 防塵裝置：使用迷宮環設計，工作中鐵屑及切削液不易進入夾盤內部，使夾盤延長使用壽命與精度保持。
- ◎ 內藏式止逆裝置：內藏式止逆閥設計，夾持狀態下不需持續供氣也能保持夾持力，並且大幅降低工作扭矩減少負載。
- ◎ 提高轉速：回轉速度範圍從100RPM到180RPM，較高的轉速能夠對應更廣範圍的應用。
- ◎ 前置式氣缸：氣缸與夾盤直接設計，確保夾持的穩定性，更便於組裝及操作。
- ◎ 氣缸防銹處理：在潮濕及工作環境較差的情況，氣缸內部經防銹處理，不會生銹或卡死。

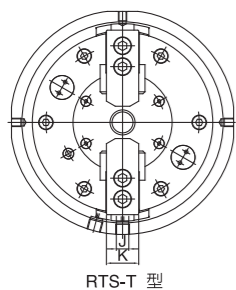

RTS-T 型

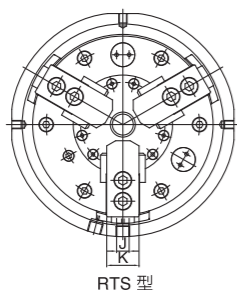

RTS 型

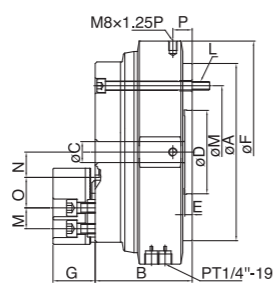

使用範例/Operation Example

規格 Spec 型號 Model	A	B	C	D	E	F	G	H	I	J	K	L
RTS-05	140	85	16	60	6	182	33.6	62	14	10	25	6-M8x1.25P
RTS-06	170	93	20	80	7	215	40.4	73	20	12	31	6-M8x1.25P
RTS-08	215	112	30	110	8	255	42.4	95	25	14	35	6-M10x1.5P
RTS-10	255	120	43	140	8	300	46.4	110	30	16	40	6-M10x1.5P
RTS-05T	140	85	16	60	6	182	33.6	62	14	10	25	6-M8x1.25P
RTS-06T	170	93	20	80	7	215	40.4	73	20	12	31	6-M8x1.25P

規格 Spec 型號 Model	M	P	N max	N min	O max	O min	通孔直徑 (mm) Thru-Hole (Diameter)	活塞面積 Piston Area (cm²)	柱塞行程 (mm) Plunger Stroke	爪行程 (直徑) (mm) Jaw Stroke (Diameter)
RTS-05	PCDØ118	18.5	26.93	24.62	20.05	6.55	16	74	10	4.6
RTS-06	PCDØ147	18.5	36.46	33.69	21.55	15.55	20	120	13	5.5
RTS-08	PCDØ185	19.5	44.92	41.52	29.55	17.55	30	190	16	6.8
RTS-10	PCDØ220	21.5	53.63	49.59	36.55	17.05	43	280	19	8.0
RTS-05T	PCDØ118	18.5	26.93	24.62	20.05	6.55	16	74	10	4.6
RTS-06T	PCDØ147	18.5	36.46	33.69	21.55	15.55	20	120	13	5.5

規格 Spec 型號 Model	淨重 Weight Kg	最高回轉速 Max R.P.M	最大設定壓力 Max. Pressure kgf/cm² (Mpa)	氣壓夾持力 Gripping Force At Air Pressure 7kgf/cm² (0.7Mpa) (KN)	夾持範圍 Gripping Range (mm)
RTS-05	10	180	7 (0.7)	1340 (13.1)	Ø4-Ø136
RTS-06	16.8	150	7 (0.7)	2330 (22.8)	Ø25-Ø166
RTS-08	30.6	120	7 (0.7)	3730 (36.5)	Ø33-Ø215
RTS-10	45.1	100	7 (0.7)	5480 (53.7)	Ø43-Ø255
RTS-05T	9.7	180	7 (0.7)	1340 (13.1)	Ø4-Ø136
RTS-06T	16.3	150	7 (0.7)	2330 (22.8)	Ø25-Ø166

\* 保留技術更改的權利，恕不另行通知 Subject to technology changes without prior information  
\* 非標準需求可訂做 Non-standard requirements can be made



## > MO MOT SERIES

### MO MOT內藏式中空(氣)油壓夾頭

#### L:加長行程 Long stroke

內藏式中空油壓夾頭適用於工作臺面的鑽銼加工工作。

- ◎ 氣缸防銹處理：在潮濕及工作環境較差的情況，氣缸內部經防銹處理，不會生銹或卡死。
- ◎ 防塵裝置：在工作臺上的鑽銼工作、切屑及冷卻液不易進入夾頭的內部，確保夾頭的使用壽命及精度。
- ◎ 內藏式油缸特性：把油缸直接裝置於夾頭內部，更能確保連接的穩定性，提升夾持力，適用於重切削及夾持精度的保持，提高加工效率。

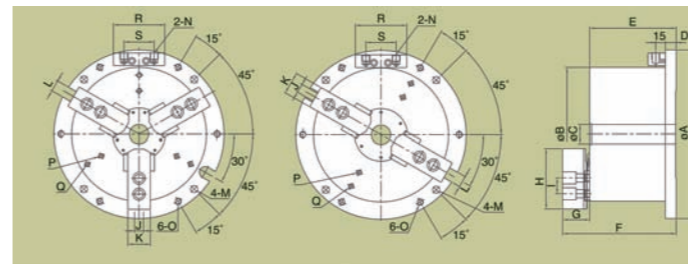

#### 應用範例：Operation example

- ◎ 氣壓切換閥連接方式及可選配件  
Examples of attaching pneumatic manual switch and optional accessories.



外接氣壓手動切換閥  
Split type hand control valve



連體氣壓手動切換閥  
Adherent type hand control valve

型號/Model 規格/Spec.	活塞面積 Piston Area (cm²)	柱塞行程 Plunger Stroke (mm)	爪行程(直徑) Jaw stroke (Dia.) (mm)	最大靜夾持力 Max. clamping force KN	最大油壓力 Max. oil pressure Kgf/cm²	空壓夾持力(KN) Gripping force at 0.7MPa	淨重(Kg) N.W	夾持範圍 Gripping Range
MO-04	57	9	3.8	23.5	15	10.8	7.05	9-115
MO-05	74	10	5.4	32.2	20	12.7	11.2	12-135
MO-06	97	12	5.5	49.4	20	19.6	21	15-169
MO-08	156	16	7.4	79.4	20	32.3	36.8	20-210
MO-10	235	19	8.8	119.7	20	47	56.4	33-254
MO-12	292	23	10.6	142.1	20	50	88.5	40-304
ML-08	156	16.5	12	51	20	18	37.6	20-210
MOT-04	57	9	3.8	18.6	12	10.8	6.9	9-115
MOT-05	74	10	5.4	25.6	16	12.7	11.2	12-135
MOT-06	97	12	5.5	39.5	16	19.6	21	15-169
MOT-08	156	16	7.4	63.5	16	32.3	36.8	20-210
MOT-10	235	19	8.8	95.6	16	47	56.4	33-254

型號/Model 規格/Spec.	A	B	C	D	E	F	G	H	I
MO-04	157	115		15	77.5	104	26	49.5	14
MO-05	185	135		15	95	128	33	62	14
MO-06	224	169	25	16	118	158	40	73	20
MO-08	265	210	30	20	138	180	42	95	25
MO-10	315	254	52	23	150	196	46	110	30
MO-12	375	304	80	23	165	219	54	129	30
ML-08	265	210	30	20	138	180	42	95	25
MOT-04	157	115		15	77.5	104	26	49.5	14
MOT-05	185	135		15	95	128	33	62	14
MOT-06	224	169	25	16	118	158	40	73	20
MOT-08	265	210	30	20	138	180	42	95	25
MOT-10	315	254	52	23	150	196	46	110	30

型號/Model 規格/Spec.	J	K	L	M	N	O	P	Q	R	S
MO-04	10	23	13	9(PCD 135)	PT1/8	M8	3-M8(PCD 90)		64	47
MO-05	10	25	13	9(PCD 165)	PT1/4	M8	3-M8(PCD 100)		80	47
MO-06	12	31	18	11(PCD 202)	PT1/4	M10	3-M8(PCD 134)		80	47
MO-08	14	35	18	11(PCD 243)	PT1/4	M10	3-M10(PCD 136)	3-M10(PCD 186)	80	47
MO-10	16	40	18	13(PCD 285)	PT1/4	M12	3-M12(PCD 170)	3-M12(PCD 230)	80	47
MO-12	21	50	18	17(PCD 340)	PT3/8	M16	3-M12(PCD 200)	3-M12(PCD 260)	80	55
ML-08	14	35	18	11(PCD 243)	PT1/4	M10	3-M10(PCD 136)	3-M10(PCD 186)	80	47
MOT-04	10	23	13	9(PCD 135)	PT1/8	M8	2-M8(PCD 90)		64	47
MOT-05	10	25	13	9(PCD 165)	PT1/4	M8	2-M8(PCD 100)		80	47
MOT-06	12	31	18	11(PCD 202)	PT1/4	M10	2-M8(PCD 134)		80	47
MOT-08	14	35	18	11(PCD 243)	PT1/4	M10	2-M10(PCD 136)	2-M10(PCD 186)	80	47
MOT-10	16	40	18	13(PCD 285)	PT1/4	M12	2-M12(PCD 170)	2-M12(PCD 230)	80	47

\* 保留技術更改的權利，恕不另行通知 Subject to technology changes without prior information  
\* 非標準需求可訂做 Non-standard requirements can be made

### > CW SERIES

#### 補償式浮動三爪卡盤

#### COMPENSATION SWING LOCK 3 JAW CHUCK



- ◎ 防鐵屑與冷卻液，防止污染內部結構。
- ◎ 卡盤本體與部件經淬火處理，採用長效潤滑，確保高精度與較長的使用壽命。
- ◎ 離心力補償，適合高-低壓夾緊。
- ◎ An internal floating cam makes it possible to clamp on the standard center hole even when the outer diameter of a work piece is not centered.
- ◎ Features a fully sealed structure that extends lubrication intervals and prevents coolant infiltration.
- ◎ Suitable for higher or lower pressure gripping working.

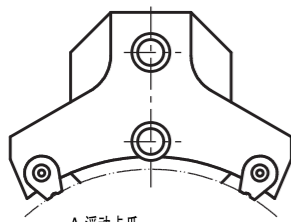
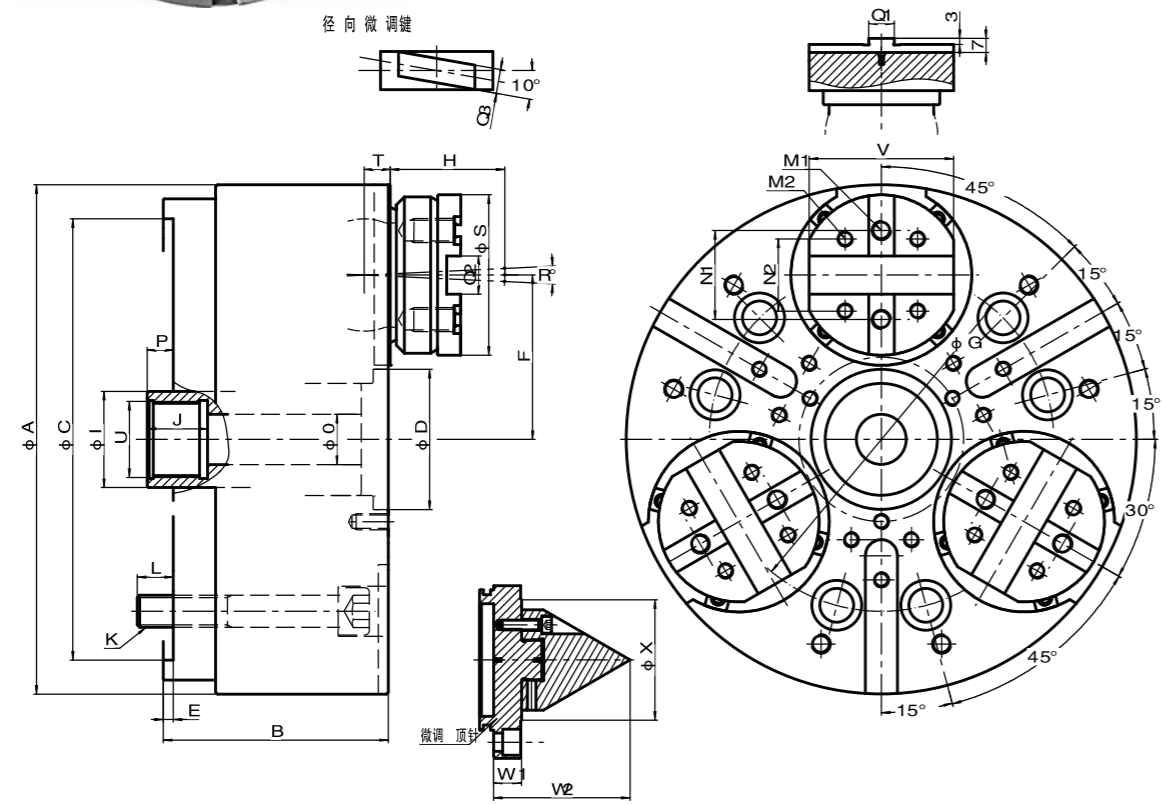

-A 浮動卡爪:  
用于夹持 毛坯或易变形工件,  
6点接触, 用于一序和二序加工;

Pedulum Jaws  
6 points touching  
For Gripping casting blank  
parts or easy deformed parts

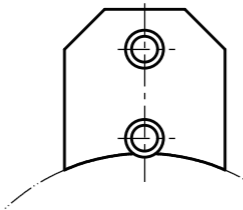

-B 刚性卡爪,  
用于夹持已加工过的直径,  
重复定心精度高。

Steel Jaws  
For clamping turned parts  
High repeatability accuracy

### > CW SERIES

#### 補償式浮動三爪卡盤

#### COMPENSATION SWING LOCK 3 JAW CHUCK

- ① 後拉工件至參考定位上;
- ② 卡爪補償夾持: 1補償夾持-2後拉-3夾緊
- ③ 尾座提供支撐零件所必需的力, 卡盤把工件拉向中心頂尖, 這樣工件不易彎曲, 加工出來的軸同心度非常好。

Pull back the workpiece to the proper position  
3 clamping process: 1st compensation gripping,  
2nd pulling back, 3rd gripping tight

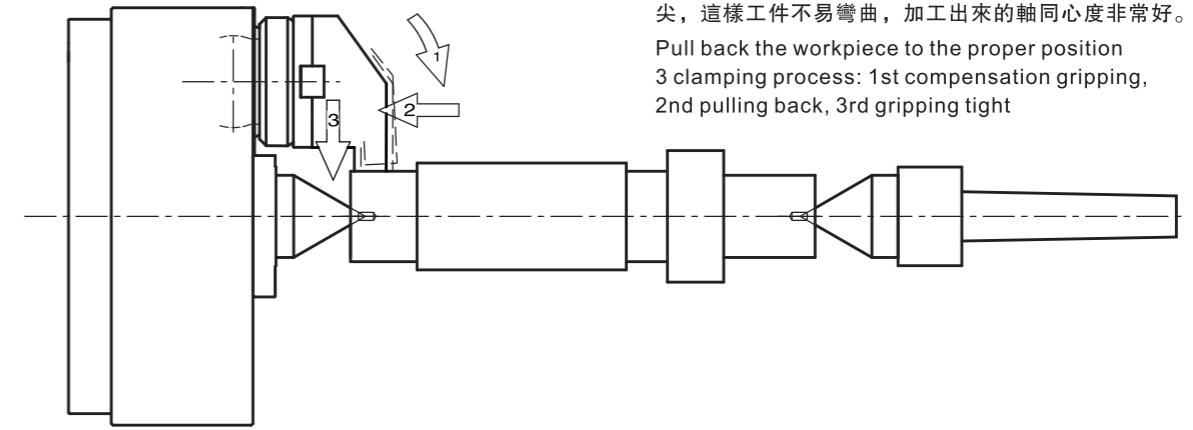

型號/Model 規格/Spec.	A	B	C (G7)	D (H8)	E	F	G	H	I	J	K
CW-05	135	70	110	30.5	5	42	82.6	39	25	17	3-M10
CW-06	173	80	140	28	5	55	104.8	50	36	25	6-M10
CW-08	212	105	170	34	5	64	133.4	60	38	25	6-M12
CW-10	254	112	220	70	5	82	171.4	70	48	30	6-M16
CW-12	315	112	220	75	5	107	171.4	70	48	30	6-M16
CW-15	390	132	300	85	5	130	235	80	75	30	6-M20
CW-21	535	138	380	85	6	190	330.2	80	75	30	6-M24
CW-24	650	155	380	150	6	245	330.2	100	100	36	6-M26

型號/Model 規格/Spec.	L	M1	M2	N1	N2	O	P	Q1(H8)	Q2(H7)	Q3(H7)	R
CW-05	15	M6	M5	19	15	8.5	0-16	6.35	7.94	5	5°
CW-06	16	M10	M8	32	24	12.5	7.5-28.5	7.94	12.68	9	5.2°
CW-08	17	M12	M10	38	32	18	7.5-32.5	12.68	12.68	9	5.2°
CW-10	18	M12	M10	44.4	36	25	0.5-25.5	12.68	19.03	12	5.4°
CW-12	18	M12	M10	44.4	36	25	12.5-37.5	12.68	19.03	12	5.4°
CW-15	26	M16	M12	63.5	48	52	10-40	12.68	19.03	12	4.7°
CW-21	29	M16	M12	63.5	48	52	5-35	12.68	19.03	12	4.7°
CW-24	29	M20	M16	63.5	54	72	4-36	12.68	19.03	12	5°

型號/Model 規格/Spec.	S	T	U	V	W1	W2	X
CW-05	37	5	M20*1.5	36	3.2	22.5	12
CW-06	60	9	M28*1.5	55	11	62	35
CW-08	75	10	M32*1.5	65	14	67	46
CW-10	80	12	M38*1.5	72	16	68	60
CW-12	80	12	M38*1.5	72	18	72	60
CW-15	105	12	M60*1.5	100	18	95	116
CW-21	105	12	M60*1.5	100	20	95	116
CW-24	127	12	M80*2	116	20	95	116

型號/Model 規格/Spec.	卡爪角行程 Jaw stroke	斜嵌軸向行程 Plunger stroke mm	最大推力 Max.Pull force KN	最大夾持力 Max.Gripping Force KN	最高轉速 Max RPM	重量 Weight Kg
CW-05	5°	16	12	29	6000	4.5
CW-06	5.2°	21	18	44	4000	15
CW-08	5.2°	25	25	60	3500	27
CW-10	5.4°	25	40	96	2800	41
CW-12	5.4°	25	40	96	2500	66
CW-15	4.7°	30	50	120	1800	115
CW-21	4.7°	30	60	150	1500	196
CW-24	5°	32	100	180	1200	386

保留技術更改的權利, 恕不另行通知。Subject to technology changes without prior information  
非標需求可訂做。Non-standard requirements can be made

### > PB-ES SERIES

#### 氣壓式動力夾頭

#### PNEUMATIC POWER CHUCK



- ◎ 適用外徑夾持之氣壓夾頭其內含氣壓缸結構。
- ◎ 具快速夾持兩段式行程。
- ◎ 具夾持時內部壓力檢知。
- ◎ 具夾持行程檢知。
- ◎ Air chuck for external clamping with built-in pneumatic cylinder.
- ◎ Fast clamping with extended jaw stroke.
- ◎ Clamping pressure control.
- ◎ Clamping stroke control.

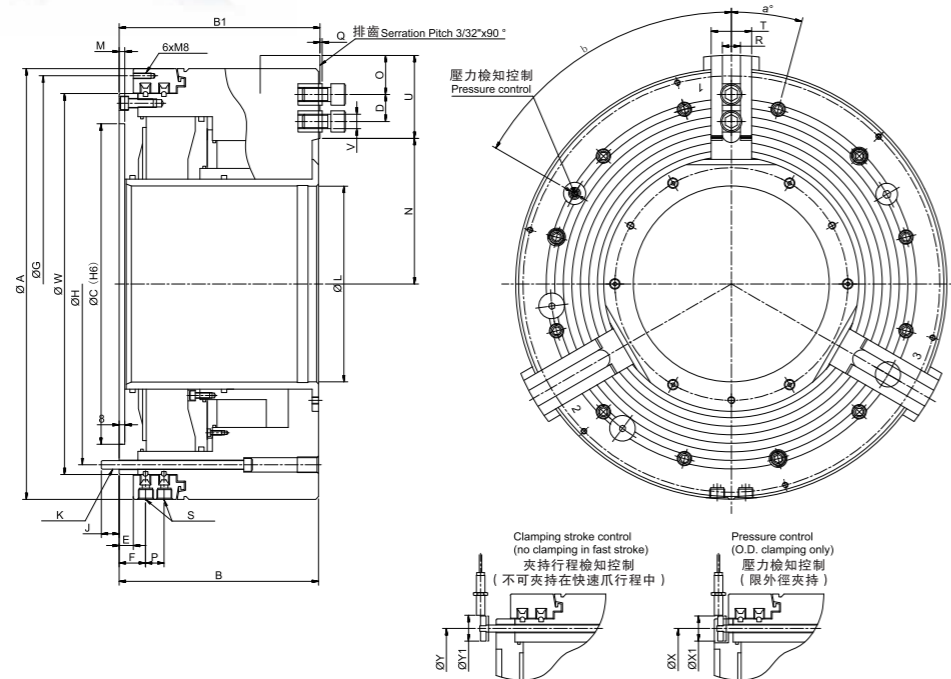

型號/Model 規格/Spec.	通孔直徑 Through hole dia. mm	總爪行程 Total jaw stroke mm	快速爪行程 Fast jaw stroke mm	夾持爪行程 Clamping jaw stroke mm	活塞面積 Piston Area cm <sup>2</sup>	使用壓力 Operating Pressure Min-Max(bar)	夾持力 Gripping Force (KN.)	最高轉速 Max RPM	重量 Weight Kg	慣性矩 I kg·m <sup>2</sup>	空氣消耗量 Air Consumption L	外徑夾持範圍 Gripping range mm
600-275	275	25.4	16.9	8.5	954	2-10	180	1100	360	20.6	39.5	135-275
850-375	375	25.4	13.4	12	1342	2-10	250	750	980	110	68	115-375

型號/Model 規格/Spec.	A	B	B1	C	D Max./Min.	E	F	G	H	J	K	L	M	N Max./Min.
600-275	605	280	282	450	79/38	20	37	585	508	25	12-M12	275	8	204.6/179.2
850-375	850	352	354	700	140/47	25	44.5	830	745	30	12-M16	375	8	268/242.6

型號/Model 規格/Spec.	O Min.	P	Q	R	S	T	U	V	W	X	X1	Y	Y1	a°	b°
600-275	14	26	3	25.5	G1/2	57	116.5	M20	535	508	35	508	35	15	16
850-375	16	33	4	30	G1/2	75	182	M24	775	745	35	745	35	15	16

備注：當使用壓力6 Bar時, Remarks: When operation pressure at 6 bar.

保留技術更改的權利，恕不另行通知。Subject to technology changes without prior information

非標需求可訂做。Non-standard requirements can be made

### > AP SERIES

#### 大孔徑中空氣動夾頭

#### LARGE THRU-HOLE AIR CHUCK

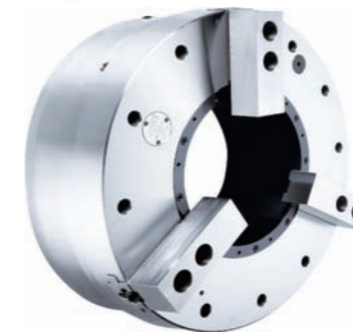

- ◎ 超大通孔氣動夾頭，內藏氣壓缸，適合管材加工。
- ◎ 夾頭內建有“壓力檢知”機構，能檢知夾頭內部壓力劇降，確保操作安全。
- ◎ 專利注氣系統，安裝快速容易，無傳統注氣密封環損壞問題，可節省安裝及維修成本。
- ◎ Large through-hole 3-jaw power chuck with built in air cylinder.
- ◎ With built-in "pressure detection" device in chuck which can check the pressure is lowered rapidly within the chuck, guarantee to the security of operating.
- ◎ Patented air supply system, it is easy to install and maintain. No abrasion issue of traditional sealed ring. Maintenance cost and time can be saved.

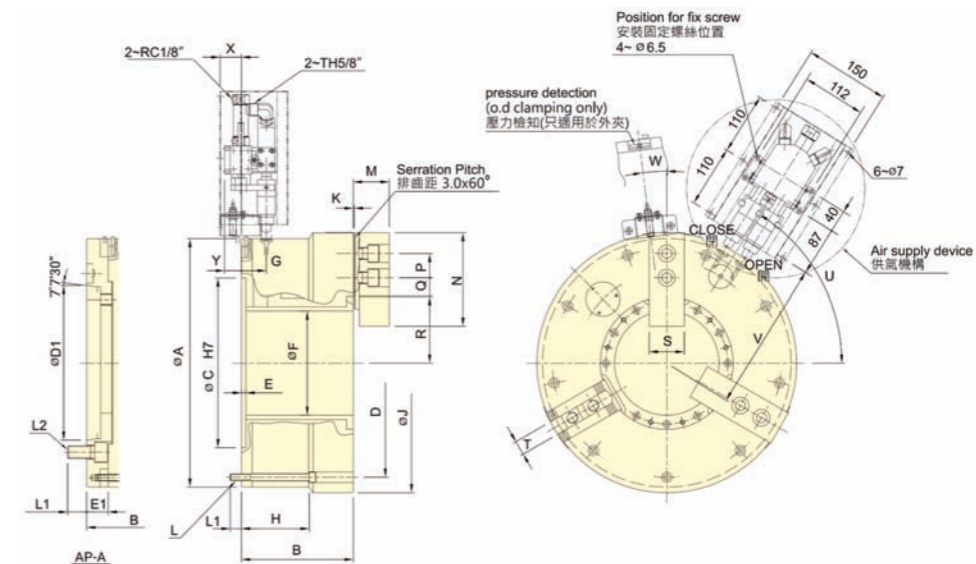

型號/Model	連接盤 Ad.	通孔 Thru-hole Dia.(mm)	爪行程直徑 Jaw stroke (Dia.)(mm)	最大夾持 Chucking Dia. Max.(mm)	最小夾持 Chucking Dia. Min.(mm)	最大壓力 Max.pressure Mpa(kgf/cm <sup>2</sup> )	最大夾持力 Max.clamping force KN(kgf)	最高轉速 Max.RPM	慣量 I kg·m <sup>2</sup>	重量 Weight (kg)	帶法蘭 重量 Weight(kg)	耗氣量 Air Consumption L
AP-145	A11	145	14	420	62	0.6 (6.1)	85.0(8667)	1700	3.8	156	182	17.8
AP-185	A15	185	14	460	100	0.6 (6.1)	110.0(11216)	1300	6	188	223	22
AP-230	A15	230	17	535	170	0.6 (6.1)	125.0(12742)	1300	11.1	265	310	34
AP-275	A20	275	17	580	200	0.6 (6.1)	140.0(14271)	1100	15.5	301	346	39
AP-320	A20	320	17	658	200	0.6 (6.1)	184.0(18762)	1000	27.2	415	505	45
AP-375	A20	375	24	738	260	0.6 (6.1)	188.0(19115)	850	44.2	530	545	55

型號/Model	連接盤 Ad.	A	B	B	C	D	D1	E	E1	F	G	H	J	K	L	L1	L1
AP-145	A11	400	198	231	300	365	196.87	8	33	145	34	120	420	3.5	9-M12	20	31
AP-185	A15	460	198	238	300	405	285.78	8	40	185	44	120	460	3.5	9-M12	20	35
AP-230	A15	515	226	266	380	483	285.78	8	40	230	49	145	535	3.5	6-M16	24	35
AP-275	A20	560	232	272	380	528	412.78	8	40	275	52	152	580	3.5	6-M16	24	35
AP-320	A20	615	256	306	520	580	412.78	8	50	320	55	116.5	658	3.5	9-M16	25	33
AP-375	A20	690	272	322	520	650	412.78	8	50	375	55	127	738	3.5	9-M16	28	33

型號/Model	連接盤 Ad.	L2	M	N	P	Q max	Q min	R max	R min	S	T	U	V	W	X	Y
AP-145	A11	6-M20	63.7	165	43	53.5	23.5	98	91	62	25.5	57°	242	0°	38	20
AP-185	A15	6-M24	63.7	165	43	53.5	23.5	118	111	62	25.5	58°	272	7°	38	20
AP-230	A15	6-M24	71.7	180	60	48.5	18.5	145	136.5	64	25.5	30°	300	7°	33	15
AP-275	A20	6-M24	71.7	180	60	48.5	18.5	167.5	159	64	25.5	30°	322	7°	30	12
AP-320	A20	6-M24	81.5	210	60	60.5	24.5	190	181.5	74	30	52°	350	7°	27	9
AP-375	A20	6-M24	81.5	210	60	60.5	24.5	223.5	211.5	74	30	52°	387	7°	27	9

保留技術更改的權利，恕不另行通知。Subject to technology changes without prior information

非標需求可訂做。Non-standard requirements can be made