

N 旋轉工作臺

C ROTARY TABLE

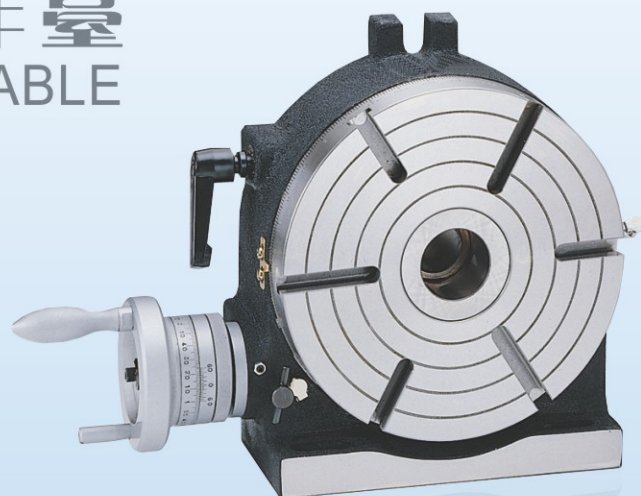

P 氣動虎鉗

NEUMATIC VISE

立卧两用分度盤 HORIZONTAL AND VERTICAL ROTARY TABLE

型号: HV-150, 200, 250, 300, 350, 400



- ◎ 此分度圆盘经360度重复定位研磨，以增加其精准度；蜗轮经热处理以增加其延展性，蜗轮比为90:1。
- ◎ 转动手轮一圈，分度圆盘转动4度。
- ◎ The work table is graduated 360 degree around its circumference and driven by a precision Worm and gear providing a 90:1 reduction ratio.
- ◎ One turn of the handle moves the table through 4 degrees. The dial is graduated in division of 1 min. and the vernier scale allows reading down to 10 seconds.
- ◎ The worm is hardened and precision ground to minimize wear out of the worm gear.
- ◎ Both the upper and the lower surface of the rotary plates are precision ground.



- 选购配件
Operational accessories
- ◎ 尾座 Tailstock
 - ◎ 蜂巢板 Dividing plate set
 - ◎ 三爪 3-jaw chuck

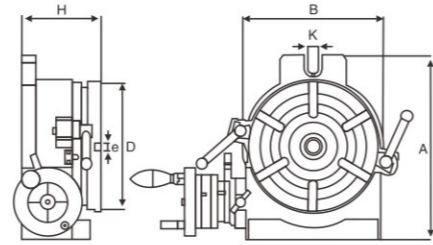

规格表

型号 Model	圆盘 Table D	底座 Base H	固定溝槽 Bolt Slot A	T型溝槽 T Slot B	中心軸套 Center Sleeve K	蜗輪比 Worm gear Ratio e	Type	立式承載力 Vertical Loading	卧式承載力 Horizontal Loading	重量 (kg) Weight
HV-150	150	92	220	160	18	11	⊙	20	39	13
HV-200	200	120	310	225	18	13	⊗	44	87	29
HV-250	250	120	320	280	18	13	⊗	62	123	41
HV-300	300	140	410	325	18	16	⊗	98	195	65
HV-350	350	140	460	380	18	16	⊗	147	294	98
HV-400	400	140	510	435	18	16	⊗	195	390	130

HV專用尾座 HV SPECIAL TAILSTOCK

型号: TS-1,2,3

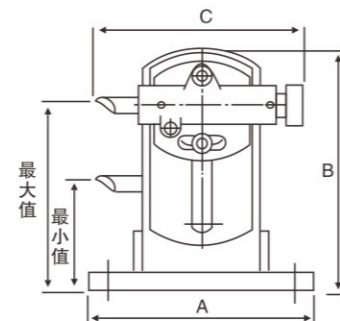

规格表

型号 Model	適用型號 Matched table	A	B	C	中心高 Center height		重量 (kg) Weight
					最大值 Max	最小值 Min	
HV-150TS	HV-150	127	110	166	113	100	5
TS-1	HV-200/HV-250	230	247	210	190	110	13
TS-2	HV-300	230	280	210	220	140	15
TS-3	HV-350/HV-400	230	330	210	264	184	17

強力型分度盤 STRONG ROTARY TABLE

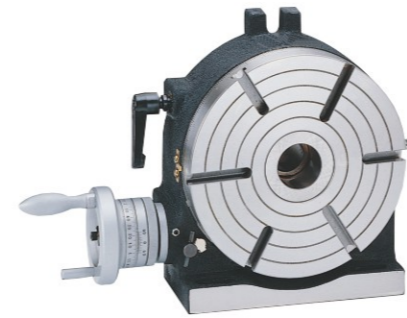

Use for air power
the revolving operation to light

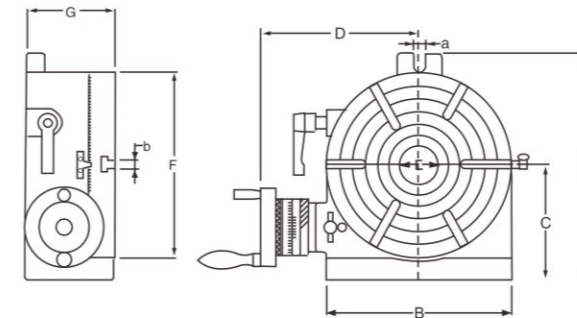
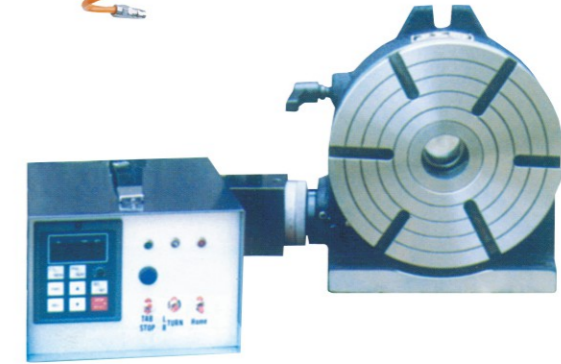
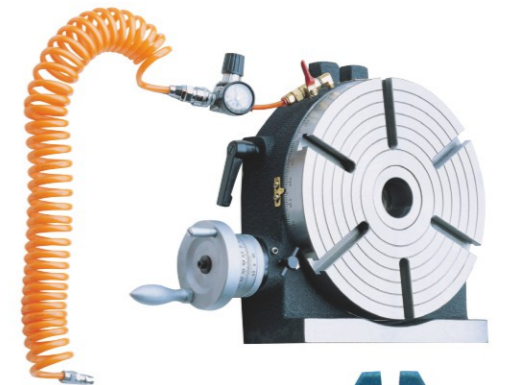

特點:

1. 本系列產品可加裝空壓系統，依載重調整轉盤即可輕輕操作旋轉“單柄兩段式鎖緊裝置，第一段可供圓弧加工調整轉盤鬆緊度，以控制加工時的震動。第二段鎖緊重切削不震動。
2. 可搭配尾座、蜂巢板使用，尾座、蜂巢板為特別附件，齒輪比為90:1，蜂巢板以CNC機械分割而成，分度準確，2-1000之分割數，均可切出。

FEATURES:

1. The machine is supported by multiple-point force and sturdy. It can overcome the downward twisting force when vertical working disc holds heavy thing.
2. Adopt single-handle and two-stage design for fastening. The first-stage can provide arc processing treatment, adjust loose and tightness of rotary disc, and control the vibration during processing. The second-stage fastening can provide non-vibrating condition during cut-off.
3. Main shaft adopt two-stage design, enlarge fore internal cavity. (we can enlarge internal cavities if necessary). After section internal cavity can help to fasten the depth control of processing products.

項次 Item	檢查項目 Inspection	允許公差 Allowable error (mm)
1	回轉盤盤面平面度 Plain-ity of rotary disc's plain surface	0.015
2	盤平面與底座的平行度 Parallel-ity of rotary disc's plain surface and pedestal	0.02
3	盤平面與垂直基部的垂直度 Vertical-ity between plain surface during rotation	0.02
4	回轉中，盤面的平面度 Plain-ity of plain surface during rotation	0.015
5	回轉牌面中心孔同心度 Concentric-ity of plain surface's center opening	0.02
6	分割精度 Cut-off precision	4.5"

Unit:m/m

型號	A	B	C	D	E	F	G	a	b	重量G.W
HV-200	280	200	150	215	50(MT4)	200	120	16	12	33kg
HV-250	310	250	155	217	50(MT4)	250	120	16	12	43kg
HV-300	365	300	180	252	50(MT4)	300	120	16	12	57kg

簡易型快速分度盤 SIMPLE INDEXING SPACER

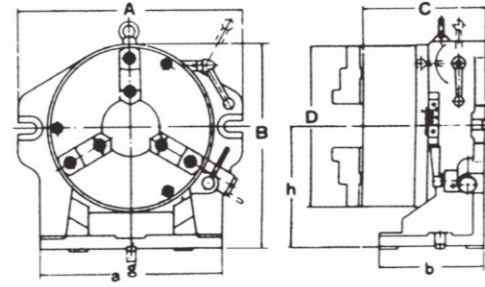

Unit:mm

型號 Model	直接分劃等分 Direct indexing	A	B	C	D	a	b	h	三爪 Three-jaw	鍵寬 Width of key(S)	外爪 Outside jaw	三爪內孔 Three-jaw inside hole	磚塔內孔 Inside hole of rotary lower	重量 N.W.
CC-6"	2.3.4.6.8.12.24	260	218	156	167	220	130	130	4-62	16	10-156	43	36	32.5
CC-8"	2.3.4.6.8.12.24	318	265	177	210	228	140	150	4-62	16	10-180	63	63	70

強力型快速分度盤 SUPER INDEXING SPACER

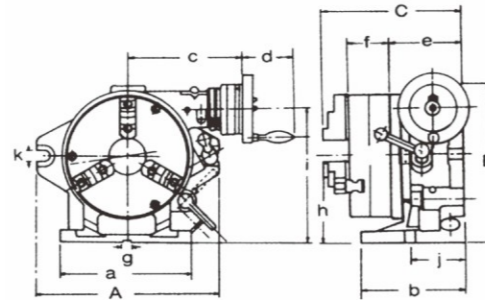
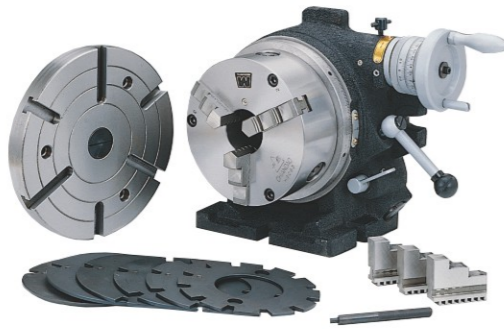

Unit:m/m

型號 MODEL	直接分劃等分 Direct indexing	三爪容量 Three-jaw capacity										面板 Face plate					
		盤外徑 Outside diameter of tray	內爪 Inside clamp	外爪 Outside clamp	中心孔徑 Diameter of central hole	外徑 Outside diameter	厚度 Thickness										
CS-6"	2.3.4.6.8.12.24	167	4-62	10-156	44	203	50										
CS-8"	2.3.4.6.8.12.24	210	4-62	10-180	63	254	58										
MODEL	A	B	C	a	b	c	d	e	f	g	h	i	j	k	重量 N.W		
CS-6"	250	235	235	220	150	184	82	112	66	16	130	186	80	18	48kg		
CS-8"	315	292	292	225	160	195	100	125	75	16	157	241	90	18	70kg		

特點:

每臺均附6個罩板可行2.3.4.6.7.8.12等六個等分數的簡單分劃，非習用之技術人員，亦可操作而不致錯誤，增加加工速度，減低精神負擔，適宜大量生產使用。

FEATURES:

Every machine has six cover plates and it can cut the thing into 2.3.4.6.8.or 12 divisions. Even the technician, who seldom uses this machine, can operate it correctly. The machine can advance the processing speed and is suitable for mass production.

分度頭 SEMI-UNIVERSAL DIVIDING HEAD

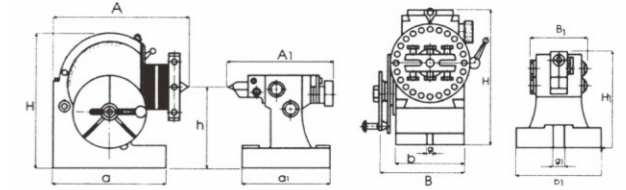
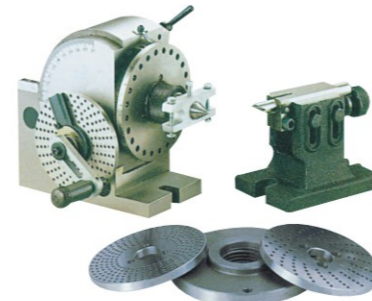

Unit:mm

型號 Model	A	B	H	h	a	b	g	中心孔 Center	軸孔徑 Dia. of spindle hole	重量 N.W.
BS-0	196	133	173	100	160	91	16	25	16	22
BS-1	253	163	220	126	207	114	16	25	20	36

型號 Model	A1	B1	H1	h	a1	b1	g1
BS-0	182	82	123	100	155	110	16
BS-1	182	82	133	126	155	110	16

OPTIONAL ACCESSORY:

3-jaw chuck: 4" or 5" 3-jaw Chuck for BS-0, 5" or 6" 3-jaw Chuck for BS-1

萬能分度頭 UNIVERSAL DIVIDING HEAD

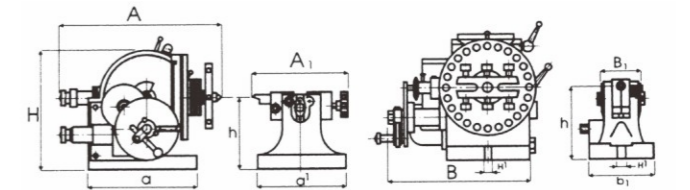

Unit:mm

型號 Model	A	B	H	h	a	b	g	中心孔 Center	軸孔徑 Dia. of spindle hole	重量 N.W.
BS-2	365	272	236	135	213	134	16	25	25.4	73

型號 Model	A1	B1	H1	h	a1	b1	g1
BS-2	182	88	156	135	175	124	16

OPTIONAL ACCESSORY:

3-jaw chuck: 6" or 7" 3-jaw Chuck for BS-2

多功能尾座 UNIVERSAL TAIL STOCK

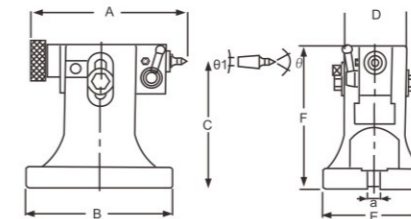

Unit:mm

型號 Model	A	B	最高 HIGHEST	最低 LOWEST	C	D	E	F	a	θ1	θ	重量 N.W.
TS-6"	192	180	170	155	140	76	126	175	16	10°	60°	9
TS-8"	192	180	195	180	165	76	126	200	16	10°	60°	10

特點:

- 1、多功能尾座，係集多種尾座之特點設計而成，使用方便，結構穩固經久耐用，可替代各型式尾座使用。
- 2、尾座採用可調式裝置，可隨心所欲，方便調整上下高度，輕而易舉。
- 3、頂針與主軸採用分離式，可配合替換各種類型頂針使用，（附標準頂針一支）可適用任何心軸，或不同類型之加工，為其他廠牌所不及。

FEATURES:

- 1、The multifunction tail stock adopts the merits of various tail stock's design. It is convenient for using, sturdy and durable. It can replace other tail stocks.
- 2、The top-bar and main shaft are separate. Users can use other top-bars. (we attach a standard top bar). It is suitable for any axes or various processing types. This design of our machine is better than those of other machines.

萬能型傾斜式分度盤 UNIVERSAL TILTING DIVIDING TABLE

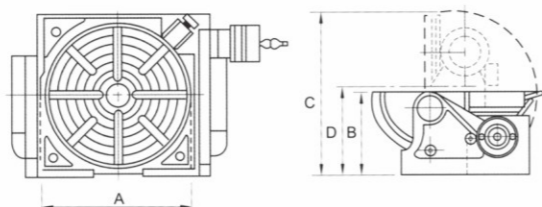
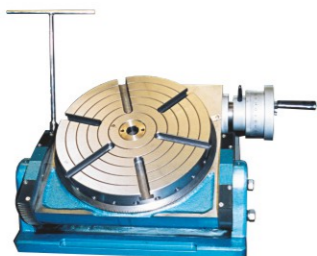

型號 Model	分割等分 Index no.	中心孔 Center	A	B	C	D	齒數比 Gear ratio	重量 N.W.
HUT-250	24	MT#3	254	172	326	172	90:1	81
HUT-300	24	MT#3	305	172	366	192	90:1	97
HUT-350	24	MT#3	355	172	306	212	90:1	118

Unit:mm

可調傾斜式角度盤 ADJUSTABLE & CK-TYPE ANGLE PLATE

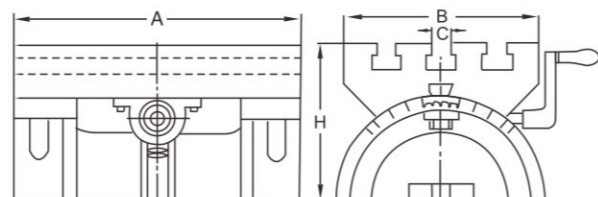

MODEL	A	B	C	H	N.W.
HAP-180	184	132	13	92	8kgs
HAP-250	260	182	16	139	22kgs
HAP-380	386	266	16	189	62kgs
HAP-600	600	305	16	215	128kgs

Unit:mm

萬能三向角度虎鉗 UNIVERSAL 3-WAY VISE

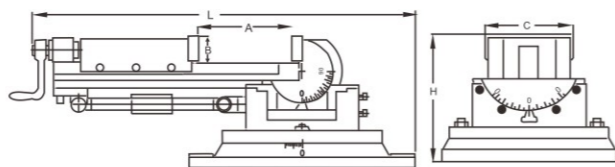

型號 Model	A	B	C	H	L	垂直時高度 Vertical height	重量 N.W.
HY-3"	90	30	80	150	396	386	15
HY-4"	105	38	105	172	460	470	32
HY-5"	140	40	132	205	625	590	50

Unit:mm

精密-角固鎖式虎鉗 PRECISION ANGLE LOCK VISE

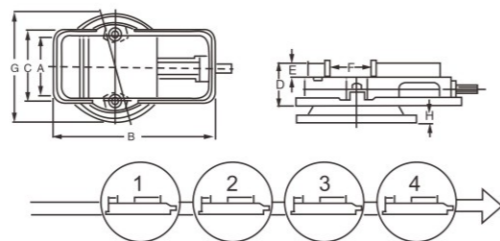

Model	A	B	C	D	E	F	G	H
HAV-4"	102	325	180	90	30	110	235	32
HAV-6"	150	420	240	117	44	150	300	42
HAV-8"	204	545	300	152	65	200	375	45

Unit:mm

MC增壓器型超高壓快速虎鉗 MC PRECISION SUPER HI-PRESSURE RAPID VISE

(全國第一臺增壓馬達虎鉗) 非一般氣壓缸型結構
The first reinforced motor vice (Non-common pneumatic cyl. structure) in Taiwan.

新產品
NEW PRODUCT



內藏空壓馬達 (專利結構)
Emersed pneumatic motor (PAT.structure)

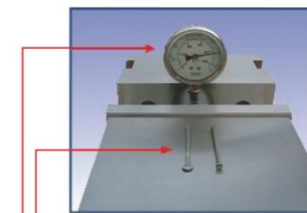

唯有自動補壓功能才能將鐵釘夾成扁平狀
Only way to press flat type nails is the automatic pressure compensate system
8kg/cm2之低壓源, 即可達9000kgf之超高挾持力
8kg/cm2 low pressure former can holding very high force up to 9000kgf

前置出力可產生雙向力減少本體變形使工件更加精準
Forward output pressure can product two-way power for reducing main body from becoming deformed and the working parts will be more accurate.

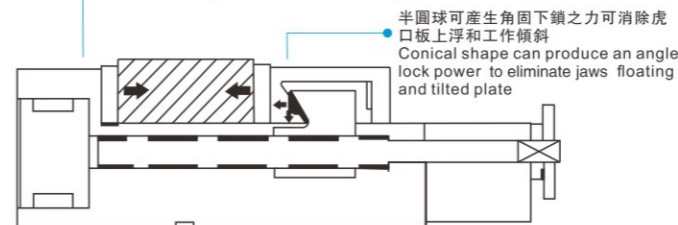

半圓球可產生角固下鎖之力可消除虎口板上浮和工作傾斜
Conical shape can produce an angle lock power to eliminate jaws floating and tilted plate

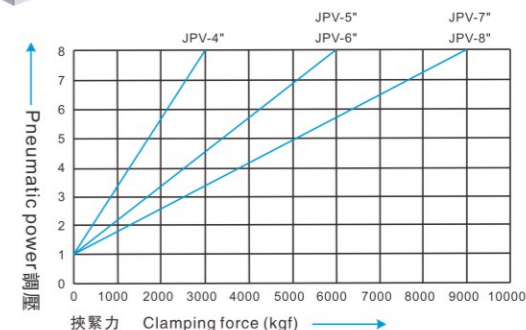

◎ 本產品已獲美國發明專利.臺灣.大陸等多國多項專利

本虎鉗原理是 用自行研發之往復式空氣馬達 (專利結構), 以氣壓連續推動油路方式, 來達成自動化, 且不需三點組合來過濾水氣, 其特性絕對為全國所僅有甚而超越國外任何廠牌。

◎ 超高挾持力

空氣源8kg/cm2之低壓源, 即可達9000kgf之超高挾持力, 而挾持力從0-900kgf可藉由調壓器自由調整設定。

◎ 自動尋找最高氣壓源

當銅鉛類產品輕加工或鑄鐵類初胚重切削時, 用調壓器設定在所需壓力, 也不會因空氣源在低點而失壓, 而且有自動補壓及穩壓之功能, 以確保工件之挾持。

◎ 最大挾持安全距離

開關速度祇需1.5秒, 挾持安全距離可達8mm, 並設有手輪安全線, 可輕易由肉眼辨識出工件挾持之安全距離, 是否超限

◎ 立、側、臥三用

定寸規格, 本體六面磨光並預留壓板槽, 不需治具板, 即可直立加工。

◎ 超高材質

虎鉗本體材質採用高延展性之石墨鑄鐵 (FCD-60) 一體成型設計。兩側滑軌經硬化熱處理 (HRC-45), 確保高精度, 高耐磨, 高抗張力。

◎ 內藏角固下壓結構

◎ This Product Is The Exclusive Patent Authorized By U.S.A, Taiwan And P.R.C

The principle of this vice is adopting the reciprocating pneu. motor (PAT.structure) which P & D by inhouse and that employs an air actuated cylinder. Circuiting progressively to make automation, no need the R.F.L unit to filter the moisture, the sole character is superior than any brand in domestic & international market.

◎ Super hi-gripping force

Even the air source at low pressure 8kg/cm2 which can be achieved super hi-gripping force 9000kgf, and the 0-9000kgf gripping force can be adjusted freely by pressure regulator.

◎ Seeking the highest air source automatically

When processed copper, aluminium etc.non-iron workpiece or raw cast iron etc.,making heavy cutting which can be made adaptable gripping force to ensure work piece clamping and with auto compensating & retaining pressure etc.,functions.

◎ The biggest safety clamping range:

The shifting speed is only 1.5 sec. with safety range :8mm, also equipped with safety line on hand wheel and can be visible the clamped work piece safety range is exceeded or not.

◎ Triple usage of vertical.side.horizontal:

Six faces of vice body be super grinding & pre-setting holding slot, and can be processed vertically without jig fixture.

◎ Super rugged material:

The vice body is adopted hi-tensile graphite casting iron (FCD-60),one piece design and harden heat-treatment (HRC45) at two slide way which ensured hi-precision, hi-durability & hi-tensile.

◎ Submersed angle fixed pressed down structure:

MC增壓器型自動雙夾虎鉗 MC SUPER HI-PRESSURE DOUBLE VISE

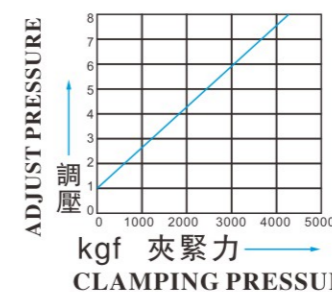
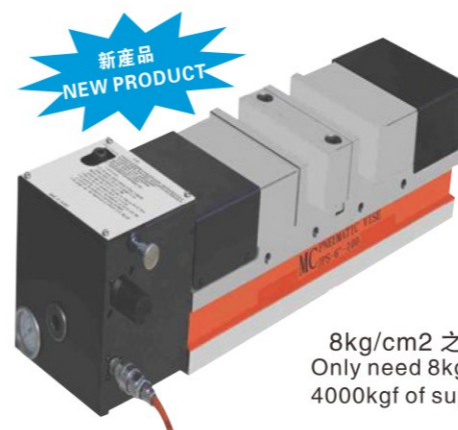

8kg/cm² 之低壓源，即可達4000kgf之超高夾持力
Only need 8kg/cm² of low air pressure source to achieve 4000kgf of super high gripping force.

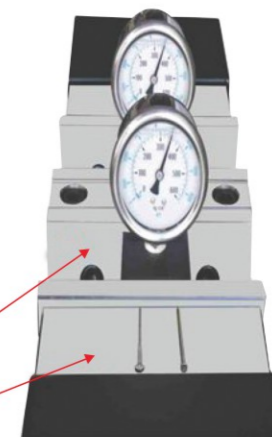

唯有自動補壓功能才能將鐵釘夾成扁平狀
By using automatic pressure compensate system to press nails into a flat type.

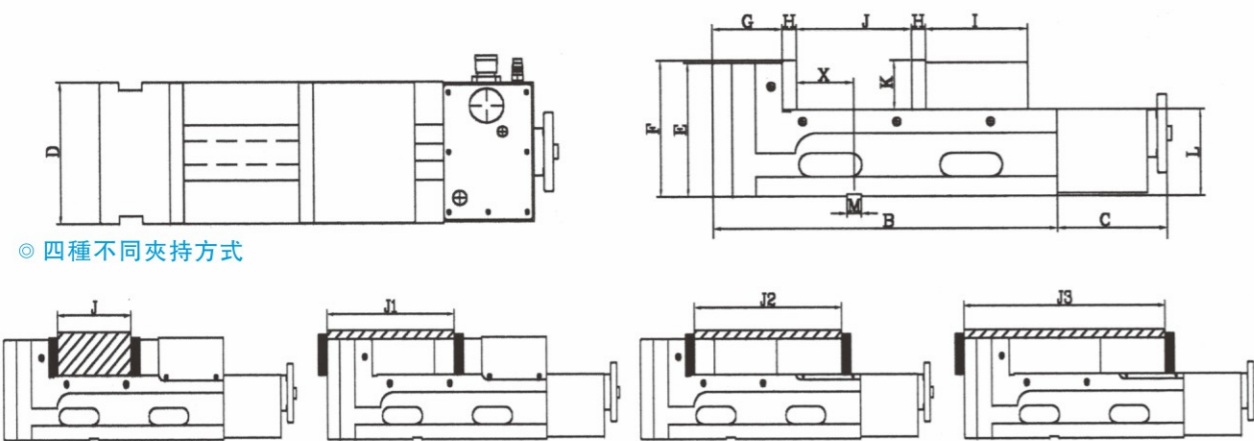

◎ 四種不同夾持方式

型號 Model	A	B	C	D	E	F	G	H	I	J	J1	J2	J3	K	L	M	X	夾持力 Gripping	淨重 N.W.(kg)	毛重 G.W.(kg)
JPV-4"-100	435	320	125	100	145	148	85	15	100	0-100	95-220	100-200	200-300	48	100	16	45	3200	27	29
JPV-5"-150	505	380	125	130	157	160	85	15	110	0-150	95-250	110-275	200-380	55	105	18	45	6000	38	40
JPV-6"-160	525	400	125	160	160	163	85	15	120	0-160	95-260	120-295	210-400	58	105	18	45	6000	48	50
JPV-6"-250	615	490	125	160	160	163	85	15	120	0-250	95-350	120-395	210-490	58	105	18	45	6000	52	55
JPV-7"-200	585	460	125	180	170	173	90	18	130	0-200	100-300	130-350	220-460	63	110	18	72	9000	65	72
JPV-8"-200	595	470	125	200	170	173	90	18	140	0-200	100-310	140-360	230-470	63	110	18	72	9000	70	80
JPV-8"-300	695	570	125	200	170	173	90	18	140	0-300	100-410	140-460	230-570	63	100	18	72	9000	79	90

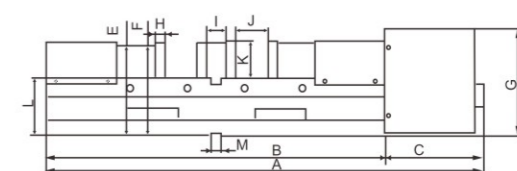

型號 Model	A	B	C	D	E	F	G	H	I	J	K	L	M	夾持力 Gripping force kgf	淨重 NW(Kg)	毛重 GW(Kg)
JPS-6"-100	682	530	152	160	145	148	168	15	30	0-100	58	90	18	400	63	66

本虎鉗原理是采用自行研發之往復式之空壓馬達（專利結構），以氣壓連續推動油路方式，來達成自動化，且不需三點組合來過濾水氣，其特性絕對為全國所僅有，甚至超越國內外任何品牌。

- ◎ **超高夾持力**
空壓源8kg/cm² 之低壓源，即可達4000kgf之超高夾持力，而夾持力從0-4000kgf可借由調壓器自由調整設定。
- ◎ **自動尋找最高空壓源**
當銅鋁類產品輕加工或鑄鐵類毛坯重切削時，用調壓器設定至所需壓力，也不會因空壓源在低點而失壓，而且有自動補壓及穩壓之功能，以確保工件之夾持。
- ◎ **最大夾持安全距離**
開關速度只需1.5秒，手自動雙夾結構，自動調整並同時夾持5mm以內兩個大小不同之工件。
- ◎ **超高材質**
虎鉗本體材質採用高延展性之石墨鑄鐵（FCD 60）一體成型設計，兩側滑軌經硬化熱處理（HRC 50），確保高精度，高耐磨，高抗張力。
- ◎ **內藏角固下壓結構**
內藏角固下壓半圓球可產生角固下鎖之力可消除虎口板上浮和工作傾斜。

This outstanding vice is adopted the reciprocating pneu. motor (PAT. structure) which is researched and developed by ourselves to push oil circuit in an air pressure actuating manner, thus obtaining automation without the R.F.L unit to filter the moisture. So, such a characteristic is unique and distinctive in domestic and international market.

- ◎ **Super high gripping force**
Only need 8kg/cm² of low air pressure source to achieve 4000kgf of super high gripping force. and this gripping force can be adjusted within 0-4000kgf by using a pressure regulator.
- ◎ **Find the highest air pressure point automatically**
When processing copper, aluminum or heavy machining raw cast iron workpiece, the pressure regulator can be set at a desired pressure without losing pressure, besides, the gripping force can be kept to clamp the workpiece securely by auto compensating and pressure stabilizing functions
- ◎ **The biggest safety clamping range**
The shifting speed is only 1.5 second. the double vise mechanism can be adjusted automatically and can simultaneously clamp two different workpieces in less than 5mm of size.
- ◎ **Super rigid material**
The body of the vice is integrally made of high tensile graphite casting iron (FCD 60) and is hardened by heat treatment (HRC 50) at its two slide way, thereby ensuring high precision, high durability and high tensile.
- ◎ **Submersed angle fixed pressed down structure**
Submersed angle pressed structure in a semi-sphere shape to produce an angle lock power, thus preventing the cutting plate from movement.

項次 NO.	檢查事項 INSPECTION ITEMS	容許可 GUARANTEED
1	虎鉗底部與滑動面平行度	0.01mm
2	夾爪端面與底部之垂直度	0.015mm
3	側邊與滑道面之垂直度	0.02mm
4	鉗口面對本座底面T型槽的平行度	0.02mm
5	鉗口面對本座底面T型槽的垂直度	0.02mm
6	測試塊夾緊後其上面對本座底面之平行度	0.02mm
7	測試塊夾緊後對本座底面之上浮量	0.015mm
8	本座直面對底面之直角度	0.02mm

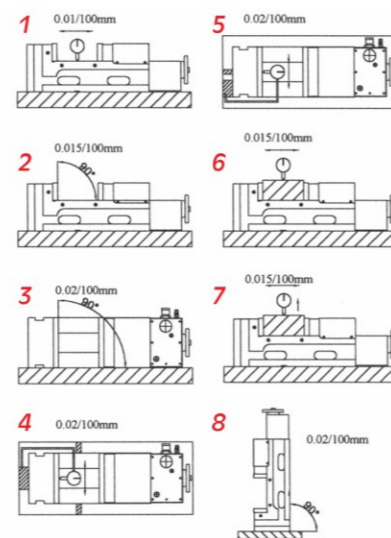

MC增壓器型浮動雙夾虎鉗 MC SUPER HIGH PRESSURE DOUBLE VISE

新產品
NEW PRODUCT



自動雙夾機構
Having automatic dual clamp mechanism

自動調整並同時夾持5mm以內兩個大小不同之工件
Automatically adjust and clamp two different workpiece within 5mm

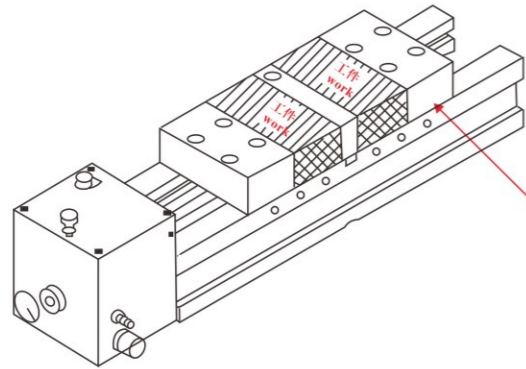

內藏浮動下壓可產生下鎖之力，可消除虎口板上浮和工作傾斜（一般由上方螺絲鎖住滑動塊的虎鉗，沒有下壓力量）

Having built in floating pressing structure to provide downward locking force to eliminate flotation of vise jaw and operational slope
(The vises which slidable block is locked by upper screw, don't occur pressing force)

8kg/cm² 之低壓源，即可達4000kgf之超高夾持力
Only need 8kg/cm² of low air pressure source to achieve 4000kgf of super high gripping force.

唯有自動補壓功能才能將鐵釘夾成扁平狀
By using automatic pressure compensate system to press nails into a flat type.



JPQ-5" JPQ-6"

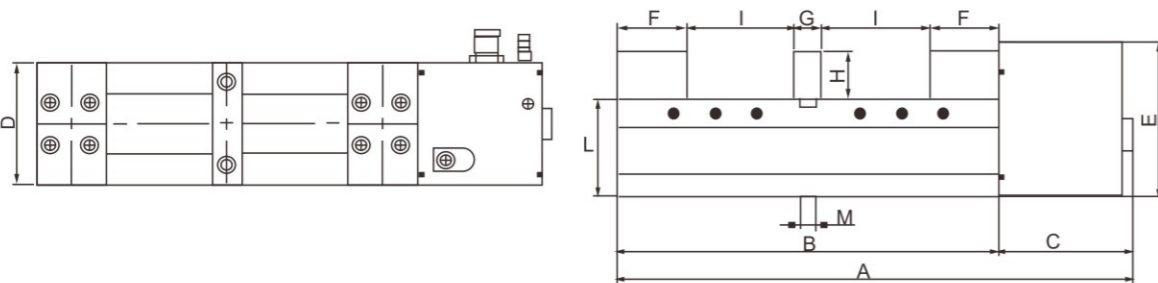
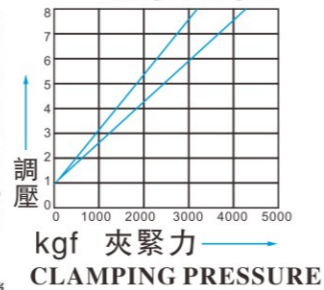

型號 Model	A	B	C	D	E	F	G	H	I	L	M	夾持力 Gripping force kgf	淨重 NW(Kg)	毛重 GW(Kg)
JPQ-5"-110	556	410	146	130	166	74	30	52	0-115	105	18	3200	42kg	44kg
JPQ-6"-150	656	510	146	160	168	82	30	55	0-155	105	18	4000	67kg	69kg

氣動油壓動力組合 AIR DRIVE HYDRAULIC OIL PRESSURE ASSEMBLE

本幫浦已獲美國發明專利.臺灣專利.大陸專利
THE pump is exclusive patent authorized by USA, TAIWAN and P.R.C

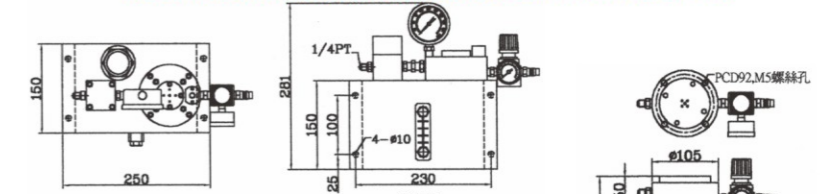

◎ 單油路 MAX. (35kg/cm²), (80kg/cm²), (210kg/cm²), (380kg/cm²), (500kg/cm²)
Single boosted MAX. (35kg/cm²), (80kg/cm²), (210kg/cm²), (380kg/cm²), (500kg/cm²)

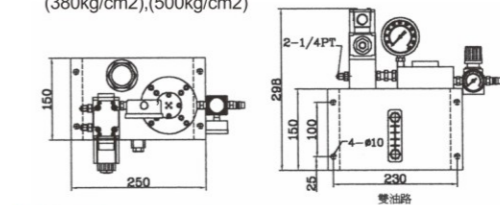

◎ 雙油路 MAX. (35KG/CM²), (80KG/CM²), (210KG/CM²)等3種壓力規格
Duble boosted MAX. (35KG/CM²), (80KG/CM²), (210KG/CM²)etc 3 pressure type.

◎ 直接放入油中可自由搭配使用

- ◎ 該型產品是自行研發設計之連續往復式增壓器,利用空壓驅動增壓浦.輸出油壓壓力.作為油壓缸之動力源.流量大於一般增壓器.動作缸無行程之限制
- ◎ 以調壓閥調整壓力,達到增壓倍數即停止驅動,油壓壓力降時,有自動補償壓力之功能,幫浦不需零件移動或增加流體溫度便能够快速獲得所需之壓力,因此節省能源.
- ◎ 特別適合於長時間油壓夾持.省能源.不產生油溫.經濟方便,幫浦在危險或受限區域中之使用不會產生電弧或火花。
- ◎ ISO 規格標準油路板及電磁閥,適用於單動或複動油壓缸.另可依實際需要再追加電磁閥.油箱體積小,節省空間,安裝容易。
- ◎ 空氣使用壓力範圍為2-8kg²最大出壓分別為。

- ◎ This type product is new design round trip sequential turbo-charger.Used of air pressure to drive the boost pump to output oil pressure.The power source of hydraulic cylinder,and it's flow is bigger than the General super-charger .The booster stoke is unlimited if you use the sequential Boost pump.
- ◎ Adjust the pressure gatge with the air regulating valve to stop driving while the Pressure is double boosted.The pump will be automatically to booster while lowering the oil pressure. The pump no need remove any part or addition temperature can be getting pressure that can be of energy-saving.
- ◎ It's fit especially for long time clamping that can be of energy-saving.no oil temperature created.Convenient and economical. The pump in dangerous or limit area used nor happen arc or flash fire.
- ◎ Standard type oil circuit board ang magnet valve conformed with the ISO's specification, simple to install and easy to maintain.It's available for using in jig range and factories. additionally it can be to booster the quantity of magnet valve depending on practical necessity.Oil tanker size small, no broken space, easy ase assemble.
- ◎ Air pressure usd range in 2-8kg² the max pressure is

五口二位迷你扣押閥 5/2 WAY MINIVALVE WITH PALM BUTTON

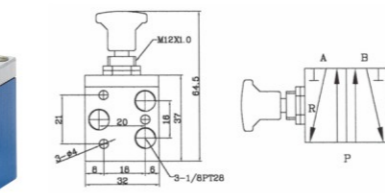

側邊型 Side-way port

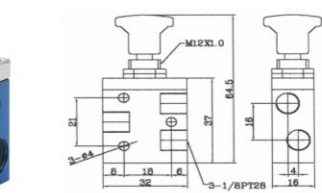

一般型 Standard